

## CONTENTS

## Page

Description .....	1
Ulvamast V3E specification .....	2
Ulvamast V3M specification.....	3
Installation.....	4
Preparation.....	5
Safety.....	6
Calibration .....	7
Spraying.....	12
After spraying.....	14
Maintenance .....	15
Fault finding .....	15
Ulvamast V3 frame diagram and parts list.....	16
Ulvamast V3E plumbing diagram and parts list .....	18
Ulvamast V3M plumbing diagram and parts list .....	20
Micron X-9 DD atomiser diagram and parts list.....	22
Ulvamast V3 filter diagram and parts list .....	23
Ulvamast V3E pump diagram and parts list.....	24
Ulvamast V3M pump diagram and parts list.....	25
Ulvamast V3 electrics diagram and parts list.....	26
Ulvamast V3 toolkit and spares.....	28
Useful references.....	29

## DESCRIPTION

The Ulvamast V3 is the latest generation of vehicle mounted ULV sprayer developed specifically for migrant pest control, particularly locusts and grasshoppers. The sprayer incorporates a number of new and innovative features and improvements including a direct drive atomiser, folding mast with locking extension arm, increased tank capacity (100 litres), stainless steel braided PTFE lined hose pipes and a choice of standard or electronic in-cab controller to regulate flow rate and atomiser disc speed. It can be powered by the vehicle battery or from a separate 12 volt DC battery for completely self-contained operation.

The sprayer consists essentially of a 100 litre tank, in-line filter and pump mounted on a nylon-coated steel framework which supports a folding mast. The Micron X-9 DD spinning disc atomiser is mounted on the mast which, when in use, protrudes beyond the back of the vehicle. An in-cab control box allows the driver to operate both pump and atomiser from within the cab for maximum safety. All materials of construction are compatible with ULV (Ultra Low Volume) formulations and resistant to ultraviolet degradation.

The Ulvamast V3 is available in two models:-

1. *Ulvamast V3E* - In-cab electronic controller with 3 atomiser speed settings and a choice of ten pre-set flow rates from 0.2 - 1.5 l/min. This eliminates the need to measure the flow rate.
2. *Ulvamast V3M* - In-cab switch box to operate the atomiser and pump. Flow control is via in-line orifice restrictor plates and adjustable needle valve with a single atomiser speed setting.

# ULVAMAST V3E SPECIFICATION

<b>Weight (empty):</b>	65 kg
<b>Operating Voltage:</b>	12 V DC
<b>Power:</b>	8 Amps maximum
<b>Frame:</b>	Stong 30 mm and 40 mm box section mild steel. Folding mast and support arm. Nylon coated.
<b>Tank (1):</b>	100 litre capacity. 5 litre graduations. Moulded metal inserts - no straps. UV stabilised HDPE.
<b>Tank (2):</b>	10 litre flushing tank.
<b>Pump:</b>	Magnetically coupled proportionating gear pump.
<b>Flow control:</b>	Electronic control. 10 preset flow rates. 0.2 - 1.5 l/min
<b>Hose material:</b>	Flexible stainless steel braided PTFE lined hose.
<b>Fittings:</b>	Plated steel brass fittings with union nut connections for maintenance.
<b>Electrical cable:</b>	Protected by black nylon conduit.
<b>Atomiser speed adjustment:</b>	Direct drive - 3 speed (electronic control) High speed - 7200 rpm Medium speed - 6000 rpm Low speed - 4500 rpm
<b>Control box:</b>	Electronic control. Master on/off. LED indicator lights - fused. 3 atomiser settings. 10 flow control settings.

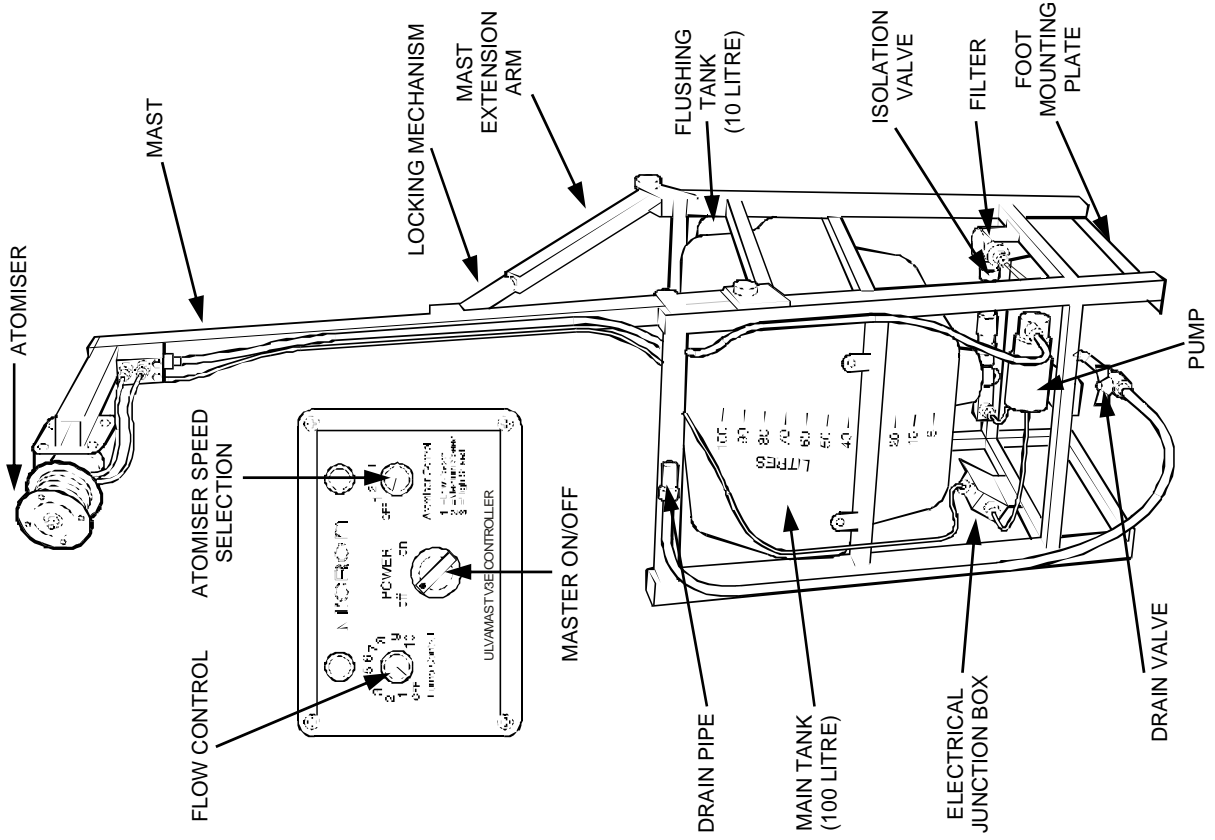

# ULVAMAST V3M SPECIFICATION

<b>Weight (empty):</b>	65 kg
<b>Operating Voltage:</b>	12 V DC
<b>Power:</b>	8 Amps maximum
<b>Frame:</b>	Strong 30 mm and 40 mm box section mild-steel. Folding mast and support arm. Nylon coated
<b>Tank (1):</b>	100 litre capacity. 5 litre graduations. Moulded metal inserts - no straps. UV stabilised HDPE.
<b>Tank (2):</b>	10 litre flushing tank.
<b>Pump:</b>	Magnetically coupled centrifugal pump.
<b>Flow control:</b>	In line orifice restrictor plates/hand operated needle valve. 0.2 - 2.0 l/min.
<b>Hose material:</b>	Flexible stainless steel braided PTFE lined hose.
<b>Fittings:</b>	Metal/brass fittings with union nut connections for maintenance.
<b>Electrical cable:</b>	Protected by black nylon conduit.
<b>Atomiser speed adjustment:</b>	Direct drive - single high speed (7200 rpm).
<b>Control box:</b>	Standard on/off pump and atomiser control. Fused with LED indicator lights.

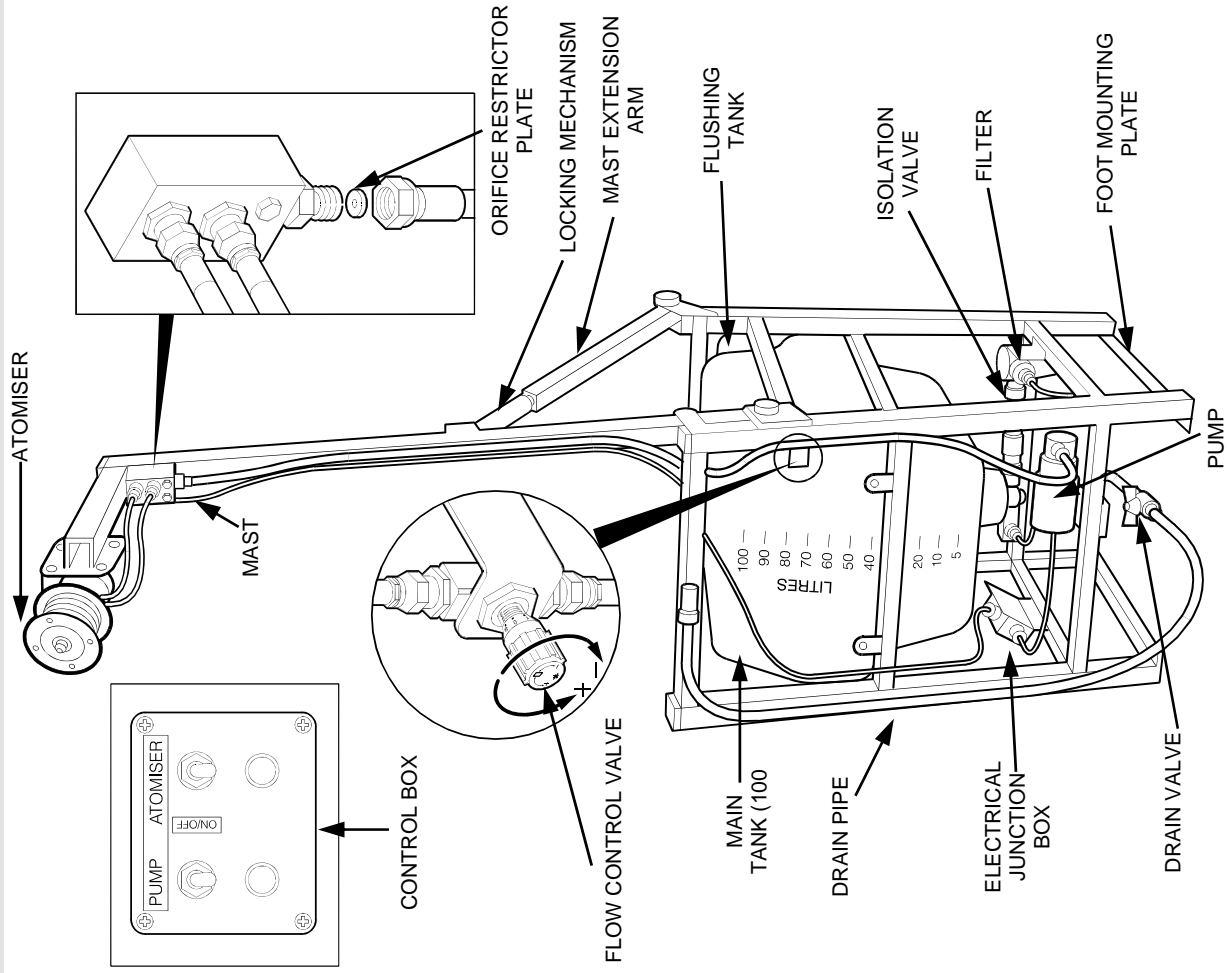

## INSTALLATION

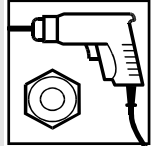

The Ulvamast can be mounted onto any open backed vehicle with an enclosed cab to protect the driver from the spray. The sprayer should be positioned as far to the rear of the vehicle as possible so that, when the mast is extended, the atomiser projects outwards beyond the back of the vehicle.

The Ulvamast should be rigidly secured to the vehicle via four holes drilled in the vehicle floor using Ulvamast foot plates with the M16 bolts, washers and nuts provided. Take care to avoid the vehicle fuel tank when drilling holes. Alternatively the sprayer can be tied down with ropes secured around the frame as a temporary installation.

The electrical supply to the Ulvamast is normally provided by the vehicle battery. The conduit containing the electrical cable should be run to the vehicle cab allowing the cable (with the control box detached) to enter the cab either through a small hole in the cab or through a window. The control box can then be located in the cab of the vehicle and connected to the battery terminals as follows:

- ◆ red/brown wire to the positive terminal +
- ◆ black/blue wire to the negative terminal -

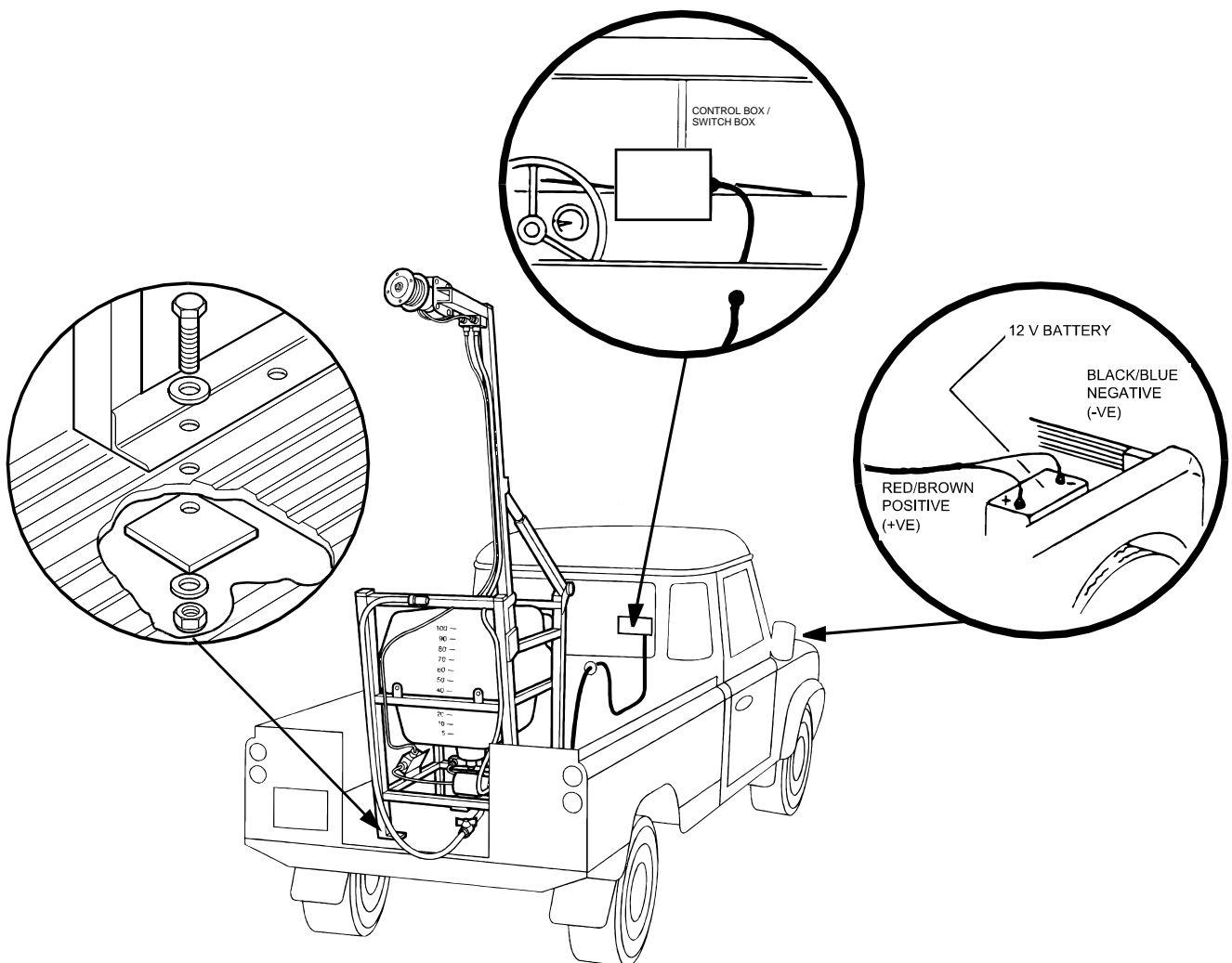

## PREPARATION

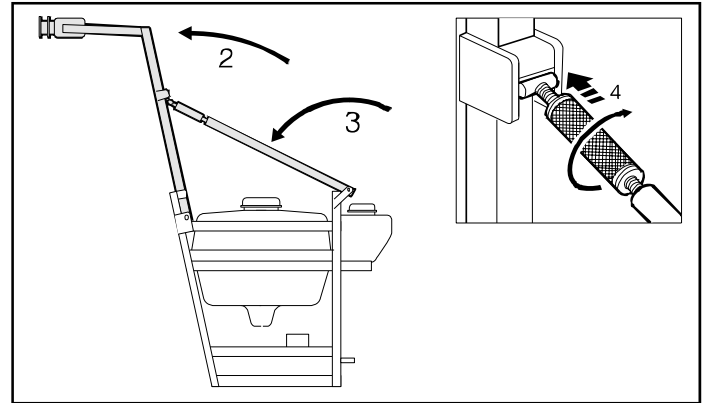
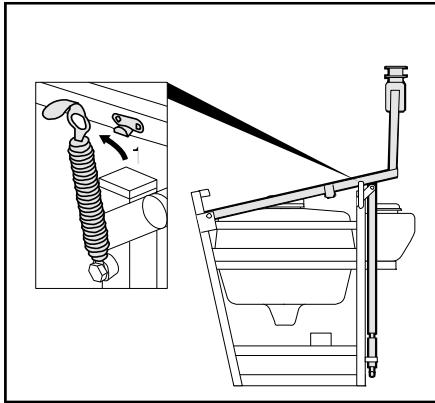

1. Unclip the retaining spring (1) and raise the mast to the operating position so that the atomiser is pointing outwards beyond the rear of the vehicle (2). Secure the mast with the extension arm (3) and lock in place by turning the locking mechanism (4).
2. Remove the protective atomiser cover and ensure that the stack of atomiser discs rotates freely when turned by hand. Store the protective cover in the back of the vehicle.
3. Check that the pump and atomiser are working by placing a small amount (5-10 litres) of kerosene or diesel oil in the 10 litre tank. Rotate the two way valve to open the 10 litre tank and make sure the isolation valve near the filter is open

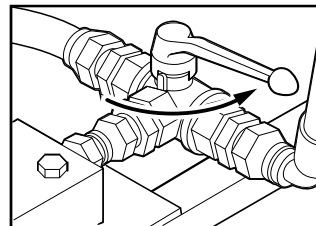

10 LITRE TANK OPEN

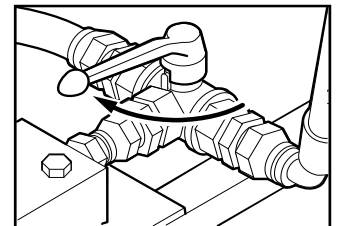

MAIN TANK OPEN

Switch on the pump at the control box. After a short period liquid should start flowing from the atomiser. Switch off the pump and then switch on the atomiser at the control box and check that it is running smoothly. Rotational speed of the atomiser can be checked with the Vibratak tachometer supplied.

### **IMPORTANT: Never run the pump dry.**

4. Check there are no leaks from any of the tubing or connections and that the drain valve is closed.
5. Check that the sprayer is properly fixed to the vehicle.
6. Before filling the main tank with pesticide, operators should wear appropriate protective clothing such as overall, boots, gloves and a face mask.
7. Proceed to fill the main tank, taking care to avoid spillages. If they do occur, wipe down the tank with a cloth soaked in diesel oil. Any spillage on the skin of the operator should be washed off immediately.

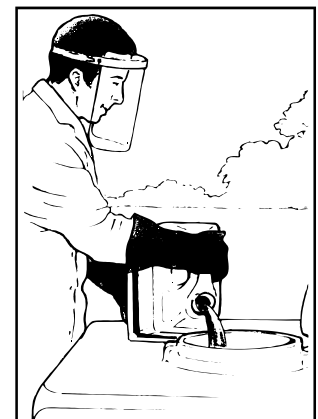

# SAFETY

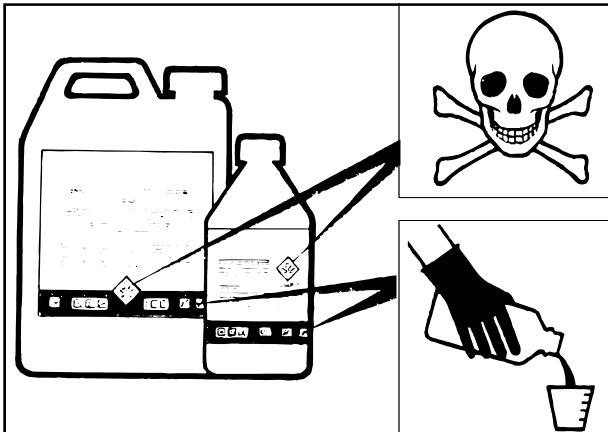

1. ALWAYS follow the safety instructions on the pesticide label when handling and using pesticides.
2. ALWAYS wear appropriate protective clothing during filling and calibration.
3. DO NOT spray near people or domestic animals. There should be no people or domestic animals within 200 metres downwind from where spraying is to take place.

4. Ensure spraying does not take place near waterways, rivers or lakes.
5. DO NOT carry people, bedding, clothing or animals in the back of the spray vehicle when spraying or when it is contaminated with pesticide.
6. NEVER carry foodstuffs in the spray vehicle.
7. ONLY use a spray vehicle fitted with an enclosed cab.

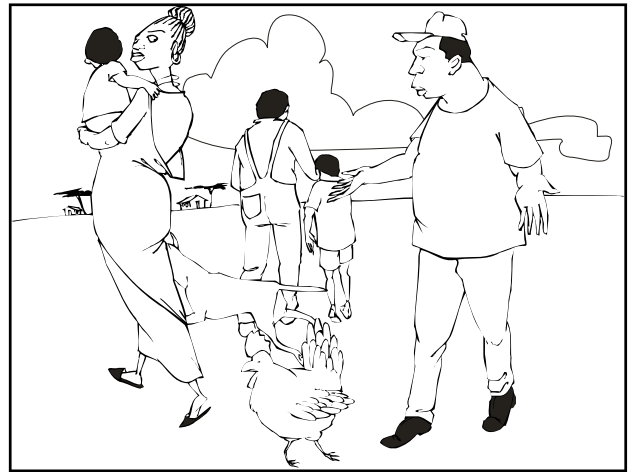

8. ALWAYS wash hands, face and body after filling the spray tank, after spraying and before eating or smoking.
9. ALWAYS carry soap and towels for washing in the cab of the spray vehicle and a supply of petrol, water and rags for cleaning the vehicle and sprayer.

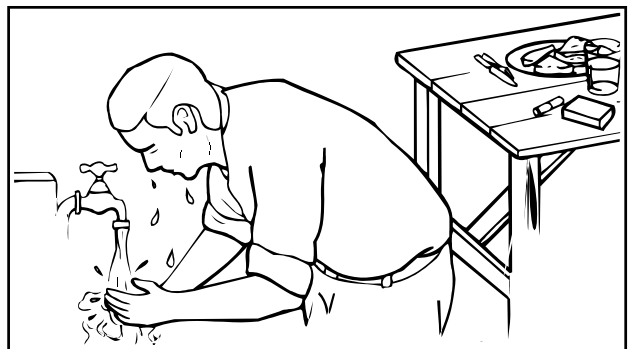

NB Acoustic information – the sound pressure level at the operator's ear, as measured inside a typical vehicle cab, is below 70 decibels therefore no ear protection is required.

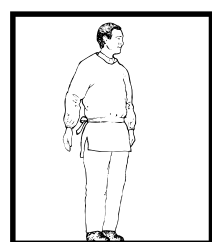
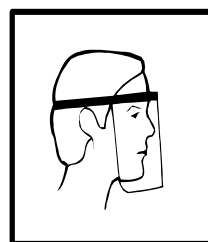
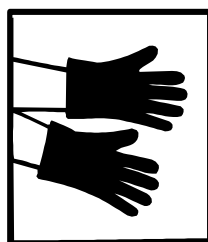
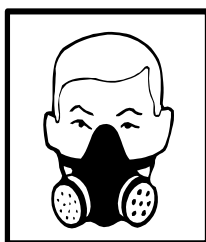

## CALIBRATION

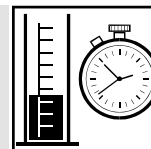

To apply the correct volume of spray liquid to an area it is necessary to accurately calibrate the sprayer. This is critically important to prevent under or over dosing. The following sequence of steps should therefore be undertaken:

### 1. Measure the forward speed of the vehicle

- select a low gear which will give a sensible speed and carry out a trial run over a measured distance of 100 metres. Time how long it takes, in seconds, to cover this distance =  $t$
- calculate your forward speed using the formula:  $\text{speed (kph)} = 360/t$

*Example: time to cover 100 metres,  $t = 36$  seconds  
then,  $\text{speed} = 360/36 = 10$  kph*

### 2. Select a suitable track spacing

The track spacing is the distance between successive spray passes of the vehicle. Spray passes should always be made with the wind at right angles to the direction of the vehicle. Although the peak spray deposit is likely to occur within 30 metres downwind some spray will be carried more than twice this distance. Spray coverage of the target area is evened out by accumulating spray deposits from overlapping swaths. This is known as an incremental spraying technique.

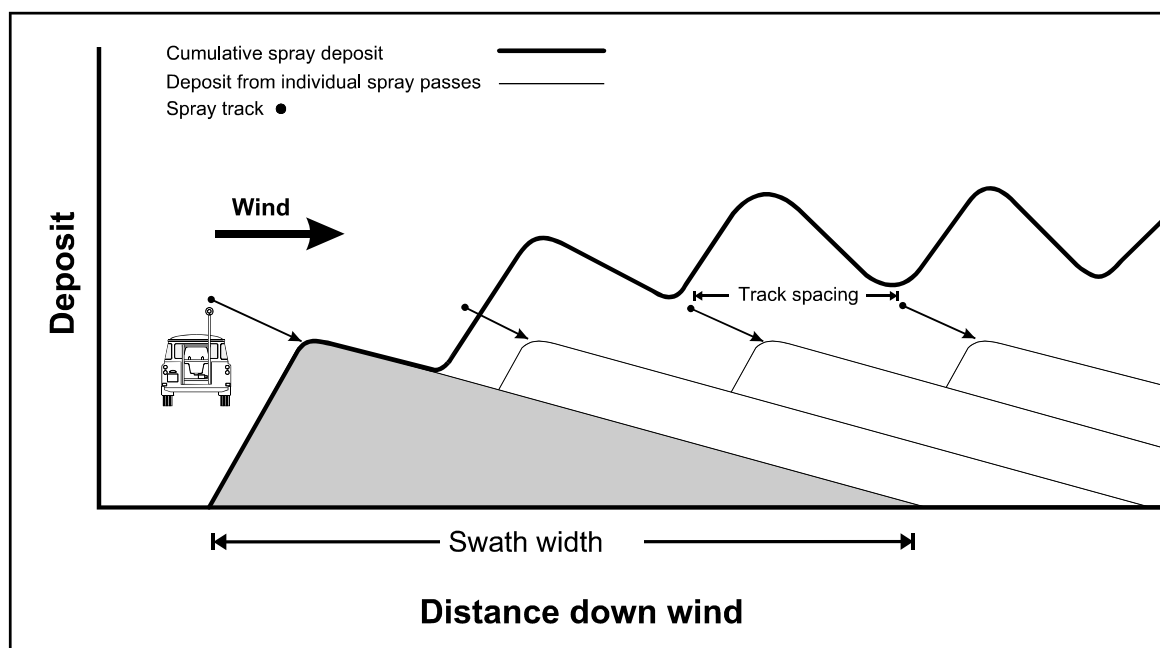

When using droplets of 50-75  $\mu\text{m}$  in diameter (high speed atomiser setting, as recommended for most applications) in a steady wind (in excess of 7 kph or 2 m/s) track spacings of 30-50 metres will be possible in sparse open areas (as found in most migrant pest control situations). Smaller track spacings will be necessary if larger droplet sizes are used (V3E model only) in lighter winds.

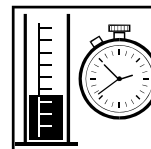

### 3. Calculate required flow rate from the atomiser

This can be calculated in litres/minute using the following formula:

$$\frac{\text{volume rate (l/ha)} \times \text{speed (kph)} \times \text{track spacing (m)}}{600}$$

(volume rate is chosen so as to apply the recommended dose of active ingredient (see FAO guidelines or manufacturers' label)

*example: if required volume application rate* = 1 l/h  
*vehicle speed* = 10 kph  
*track spacing* = 30 m

*then, required flow rate to atomiser* =

$$\frac{1 \times 10 \times 30}{600} = 0.5 \text{ l/min i.e. } 500 \text{ ml/min}$$

Table for determining required flow rate through the atomiser at a volume rate of 1 l/ha:

Track spacing (m)	Atomiser flow rate (ml/min)		
	Vehicle forward speed (kph)		
	5	7.5	10
25	208	313	417
30	250	375	500
35	292	438	583
50	417	625	833

### 4. Check intended atomiser speed and flow rate give the desired droplet size.

Feed rate (ml/min)	High speed		Medium speed (V3E only)		Low speed (V3E only)	
	RPM	VMD (µm)	RPM	VMD (µm)	RPM	VMD (µm)
0	7800	-	5200	-	4000	-
200	7600	50	-	-	3900	90
300	7400	55	5000	65	3850	95
500	7000	60	4850	75	3800	105
1000	6800	70	4700	85	3700	120
1500	6600	75	4500	95	3700	130

\*VMD = Volume Median Diameter

Tests made on Malvern 2600C Particle Size Analyser

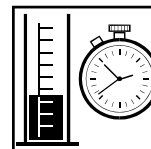

## SETTING FLOW RATE – V3M

The following sequence of steps should then be undertaken:

1. Ensure the drain valve is closed and the main tank valve open.
2. Place a clean bucket directly underneath the atomiser to collect spray liquid (the bucket can be hung from the mast arm - see next page).
3. With the engine running to ensure that the pump is working at the correct operating voltage, switch on **ONLY** the pump at the control box. **DO NOT** switch on the atomiser.
4. Open the flow control valve by turning anti-clockwise. Liquid should begin to flow from the atomiser into the bucket (operating at maximum flow rate for a short period will remove any air which may have been entrained in the hose lines and pump). Once liquid is flowing at a steady rate hold the measuring cylinder supplied underneath the atomiser and check the output over one minute (as measured using a stopwatch).
5. Adjust the flow control valve until the required flow rate is obtained. Then switch off the pump.
6. If using orifice restrictor plates, the flow valve is left in the fully open position for calibration and spraying. Referring to the table below, select and fit (as shown) the orifice restrictor plate which gives the flow rate closest to that required. Measure the flow rate. If this is too low or too high use a larger or smaller orifice plate as appropriate. Actual flow rate will vary according to the pesticide used and its temperature and thus calibration **MUST** be carried out using the actual product. N.B. the values given in the table are for oil. Actual flow rates will vary according to the pesticide used and its temperature and should be measured with actual product).

Restrictor Number	Flow rate* (ml/min) with oil
24	108
30	149
39	294
49	461
59	581
68	709
80	957
98	1210

\* flow rates will vary with liquid viscosity

7. Put all the spray liquid collected in the bucket back into the spray tank through the lid filter. **DO NOT** stand under the atomiser after spray liquid has been fed through it since dripping may occur.
8. Clean the bucket and measuring cylinder. Wash down any spillage on the tank and vehicle.
9. **ALWAYS** wash hands and face after handling pesticides.

**NOTE:** The sprayer must be re-calibrated if the forward speed, track spacing or volume application rate change. Calibration **MUST** be checked at the beginning of each day's operation.

## SETTING FLOW RATE - V3M (cont)

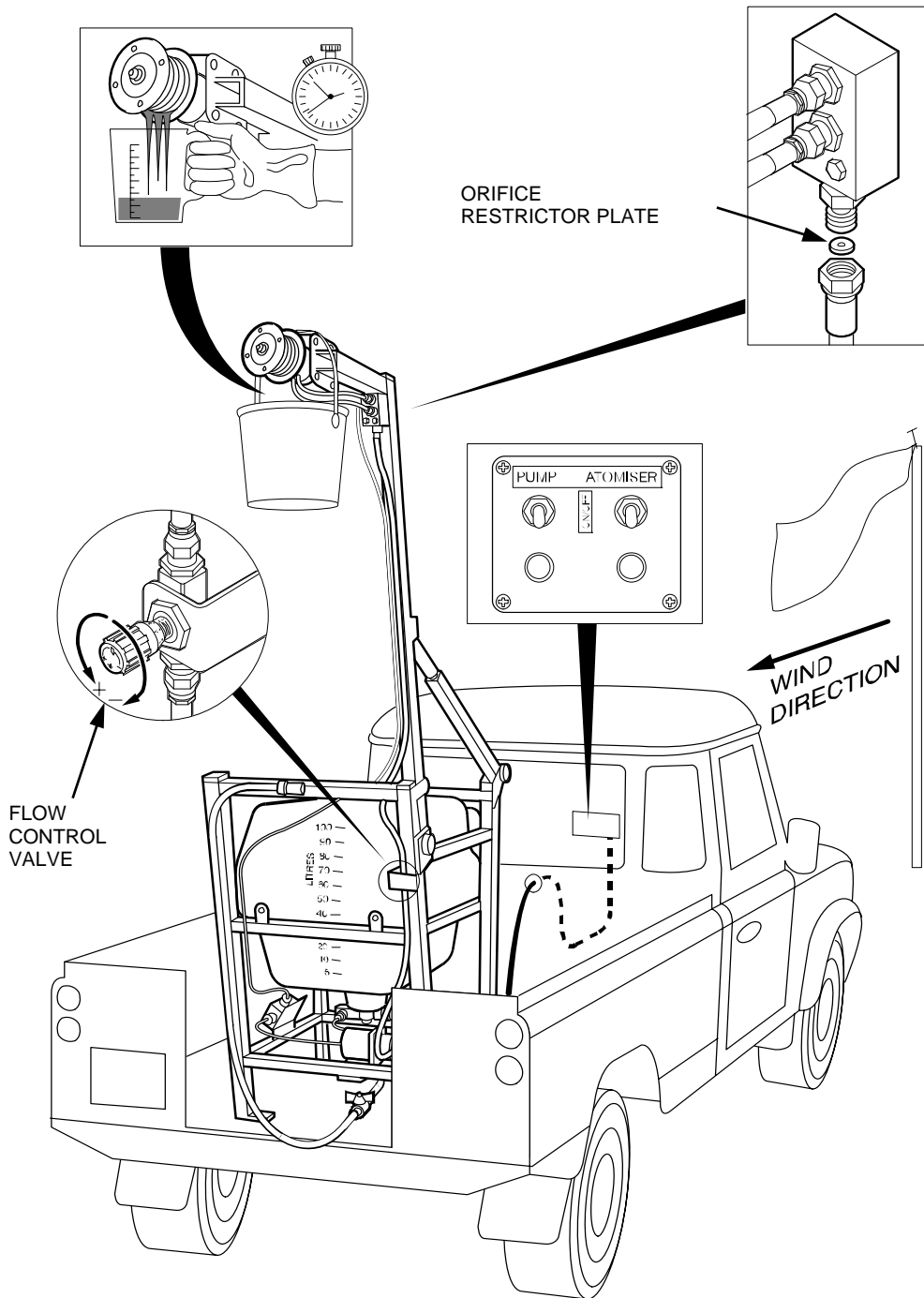
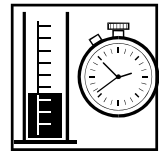

### **IMPORTANT:**

#### **ALWAYS:**

Check the flow rate with the **ACTUAL** product or spray mix, as viscosity will affect flow rate.

Follow the safety instructions on the pesticide label when handling the pesticide. It is recommended that when handling any pesticides, overalls, rubber gloves, boots and a face mask are worn.

Park the vehicle into the wind when setting the liquid flow rate to avoid any possible contamination of the vehicle, and run the engine to produce the correct voltage at the pump.

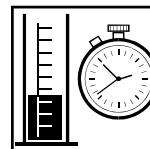

## SETTING FLOW RATE – V3E

With the V3E model, there are ten pre-set flow rates (shown in the table below) which can be 'dialed in' on the cab controller and which are independent of viscosity. There is no need, therefore, to measure the flow rate each day or when products are changed as flow control is not affected by the product used or temperature. Calibration is thus much simpler. If it is necessary to verify the flow rate follow steps 1 – 9 as for V3M (page 9) omitting steps 5 and 6.

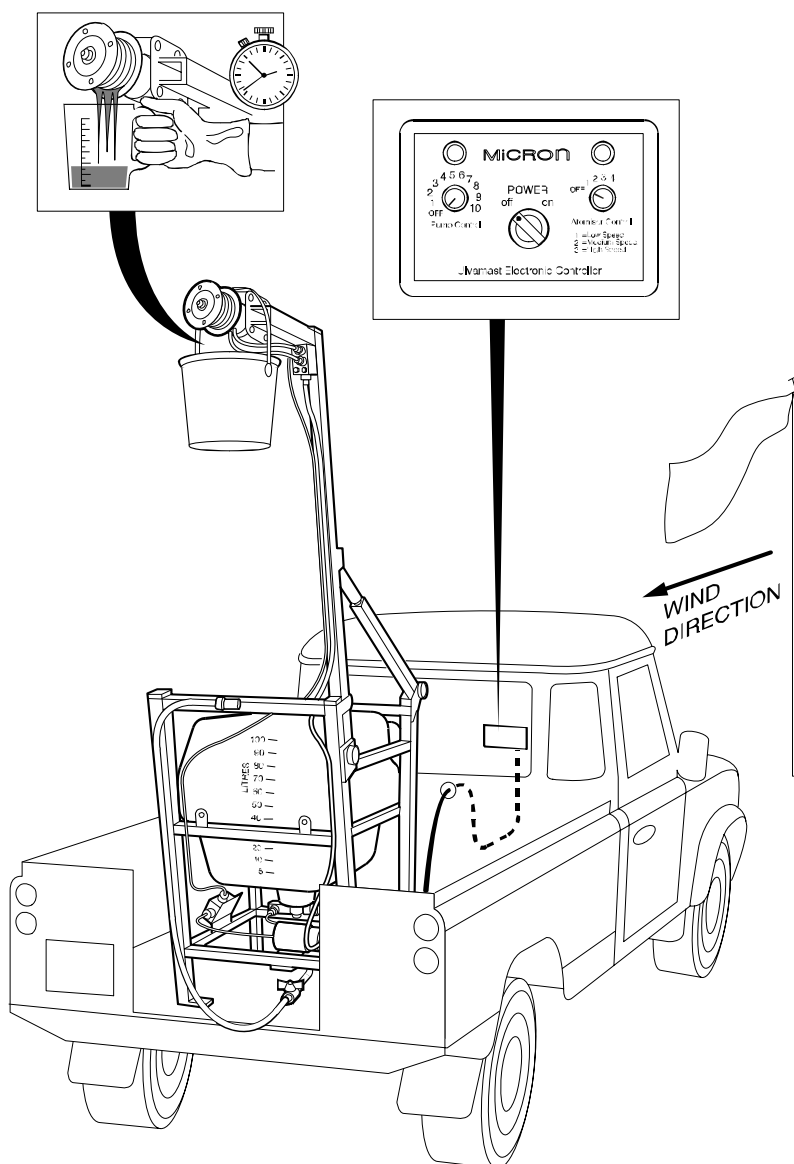

Position	Flow rate (ml/min)
1	200
2	250
3	300
4	400
5	500
6	600
7	800
8	1000
9	1250
10	1500

# SPRAYING

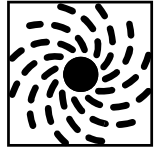

The Ulvamast V3 can be used for treating large areas (or blocks) for barrier spraying in strips (usually 500 m - 1000 m apart) or for treating individual hopper bands. The principles of operation of the sprayer are the same for each.

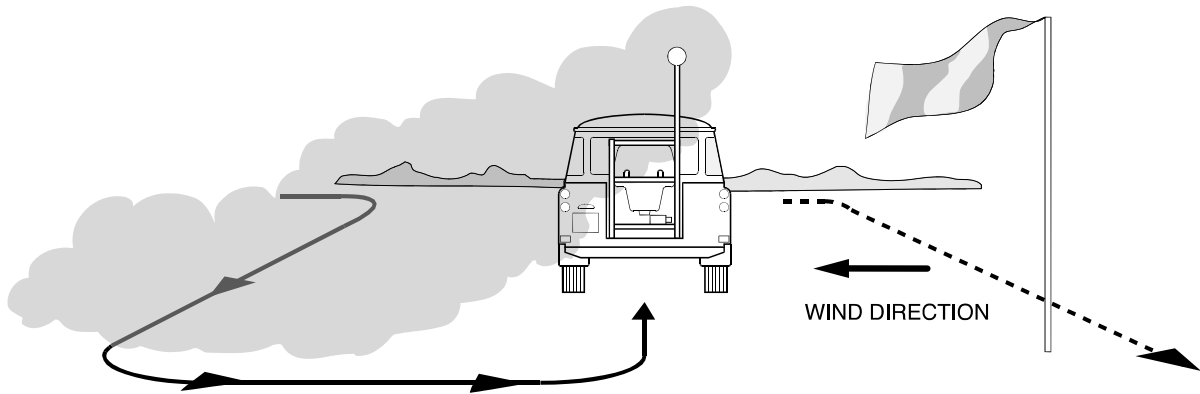

*Example: individual hopper treatment.*

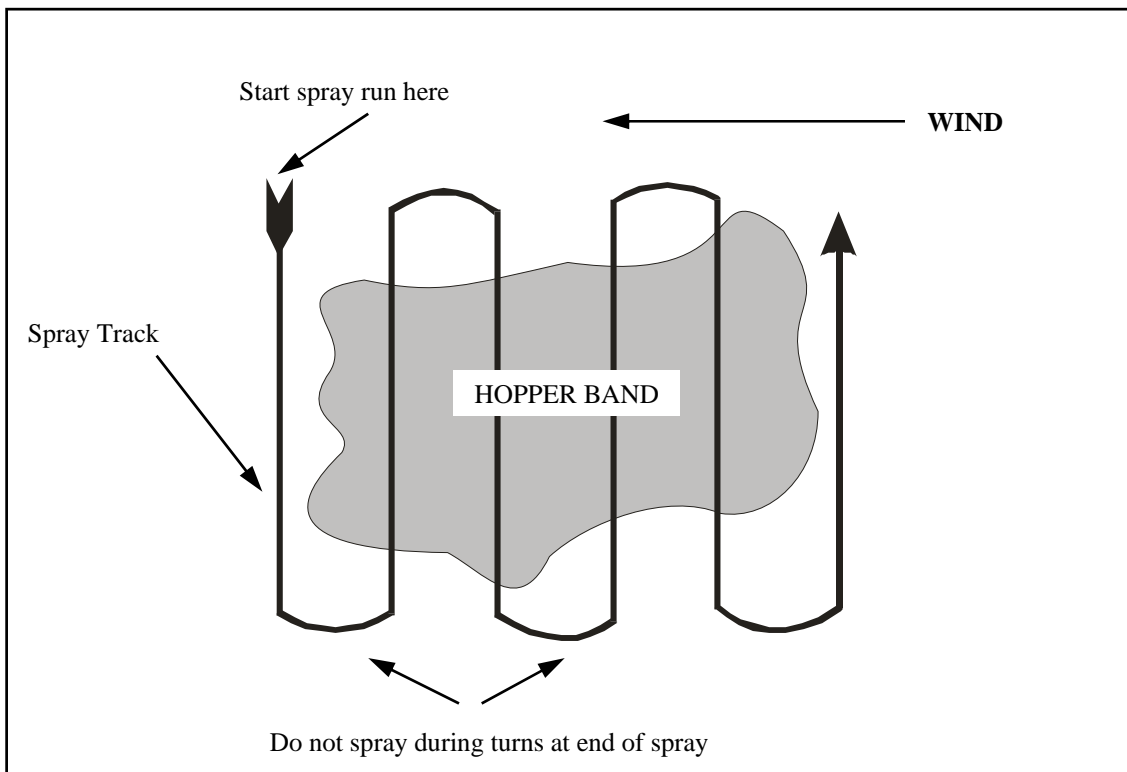

*(after FAO Control Guidelines, 1992)*

Treating medium and large bands using a vehicle-mounted sprayer: spray cross-wind starting beyond the downwind edge of the band and moving upwind after each spray pass.

The direction of the vehicle should always be at right angles to the prevailing wind direction.

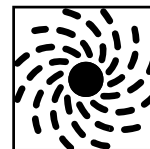

Spraying should begin at the downwind edge of the target area. If treating an individual band always start spraying beyond the leading edge of the band. Successive spray passes should then be made parallel to one another, each separated 30-50 m apart. At the end of each spray pass, the Ulvamast pump and atomiser should be turned off. The vehicle should always turn into the wind so that each successive spray pass is always upwind of the last.

If possible, it is recommended that flagmen are used to mark the track spacing at either end of the spray pass with each flagman moving upwind to the next spray pass as the vehicle approaches. Care should be taken to ensure that flagmen are never downwind of the vehicle during spraying

Even spray coverage is obtained by incremental overlapping of spray passes.

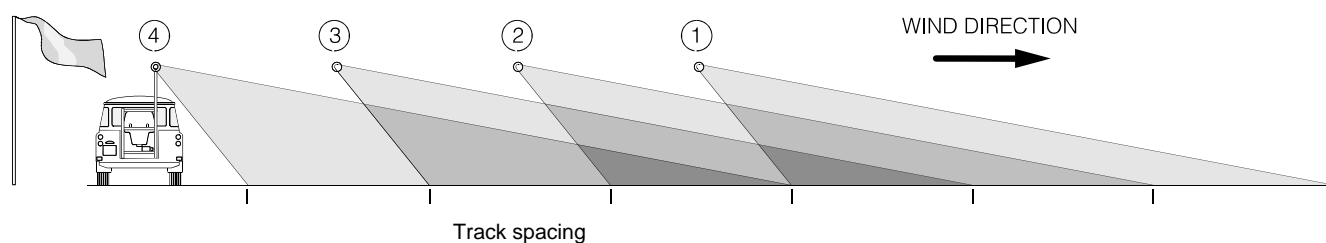

For very small hopper bands (< 0.5 ha in size), it may sometimes be more appropriate to use a hand held ULV sprayer such as the Micron Ulva+ or Micro-Ulva.

N.B. For detailed recommendations concerning the principles and procedures for spraying locusts, grasshoppers or other migrant pests, refer to the references at the end of this manual.

## AFTER SPRAYING



1. The atomiser and hose should be flushed through with a cleaning fluid, such as kerosene or diesel. Always carry 5-10 litres of kerosene or diesel oil in the smaller 10 litre tank for this purpose. Rotate the two way valve to open the 10 litre tank and close the main tank.

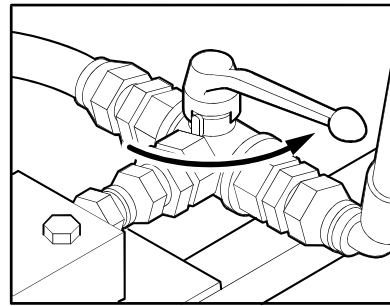

The sprayer should be taken to a clear area of non-crop land and, whilst travelling, both the pump and atomiser should be switched on for a few minutes. The drain valve may be used to remove any residue of liquid left in the plumbing system.

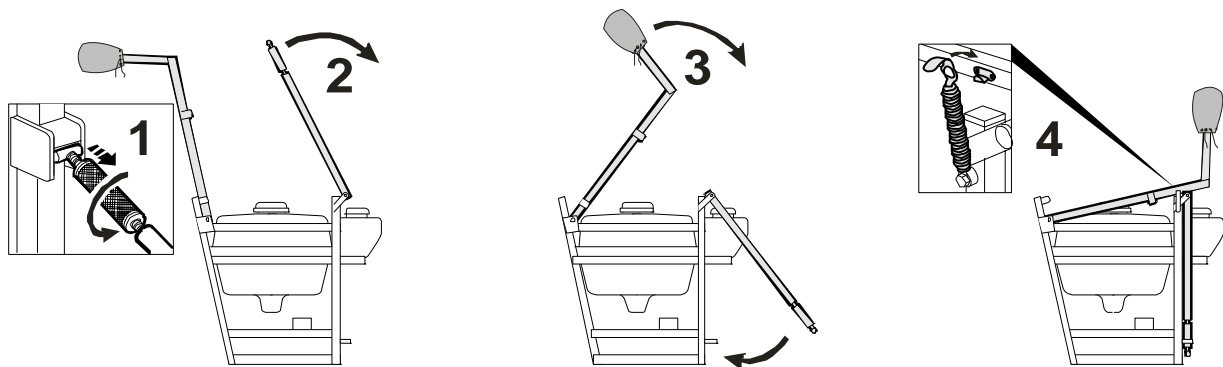
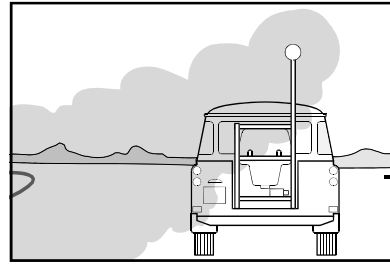

2. When spraying has finished, replace the protective cover to avoid damage to the atomiser and fold down the mast to minimise the risk of damage during transport, securing it with the spring retainer.
3. ALWAYS disconnect the cable plug from the control box when the sprayer is not in use to prevent either the pump or atomiser from being accidentally switched on.

4. If it is necessary to drain the tank, open the drain valve (T-handle along the drain pipe) to allow the spray liquid to be dispensed into a suitable container through the drain pipe. After the tank has been drained the drain valve must then be closed (T-handle at 90 degrees to the drain pipe) and secured in the closed position.

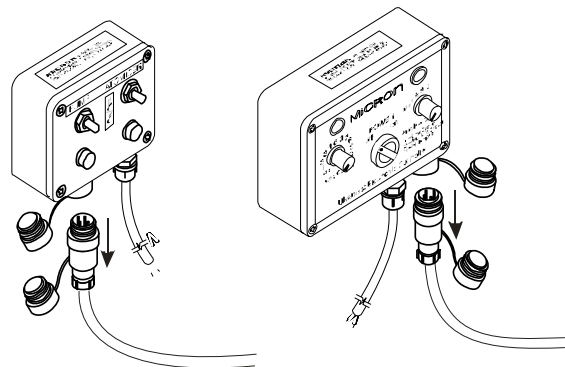

5. The sprayer should be washed down after each day to remove any spray residues and dirt. Rags soaked in kerosene/diesel or soapy water can be used to clean all external surfaces.

## MAINTENANCE



1. Regularly wipe down external surfaces with a cloth soaked in kerosene, diesel or soapy water to remove pesticide deposits.
2. Regularly flush the sprayer through with kerosene/diesel from the auxiliary 10 litre flushing tank.
3. Check hose pipe connections are secure and leak free.
4. Check atomiser spins freely and the disc stack is in good condition.
5. Never run the pump without liquid.
6. Occasionally check the in-line filter is clean.
7. During transport between sites the mast should always be secured in the folded position and the dust cover used to protect the atomiser.

## FAULT FINDING



- a) Atomiser does not work:
  - 1) check electrical connections and the fuses in the control box;
  - 2) check the battery condition;
  - 3) check if the atomiser spins freely on the motor.
- b) No flow from pump:
  - 1) check there is sufficient liquid in the tank;
  - 2) check that the in-line orifice restrictor is not blocked (V3M model only);
  - 3) check electrical connections and fuses in the control box;
  - 4) check in line filter is not blocked;
  - 5) check that pump impeller is not obstructed (motor runs but no flow). This will require disassembly of pump head (see V3M and V3E pump diagrams pages 26 and 27).
- c) Spray liquid is not being emitted from the atomiser discs:
  - 1) check that the two way valve is in the correct position
  - 2) check pump is working;
  - 3) check for plumbing leaks and/or blockages;
  - 4) check that the in-line filter is not blocked;

# ULVAMAST V3 FRAME PARTS DIAGRAM (V3E and V3M Models)

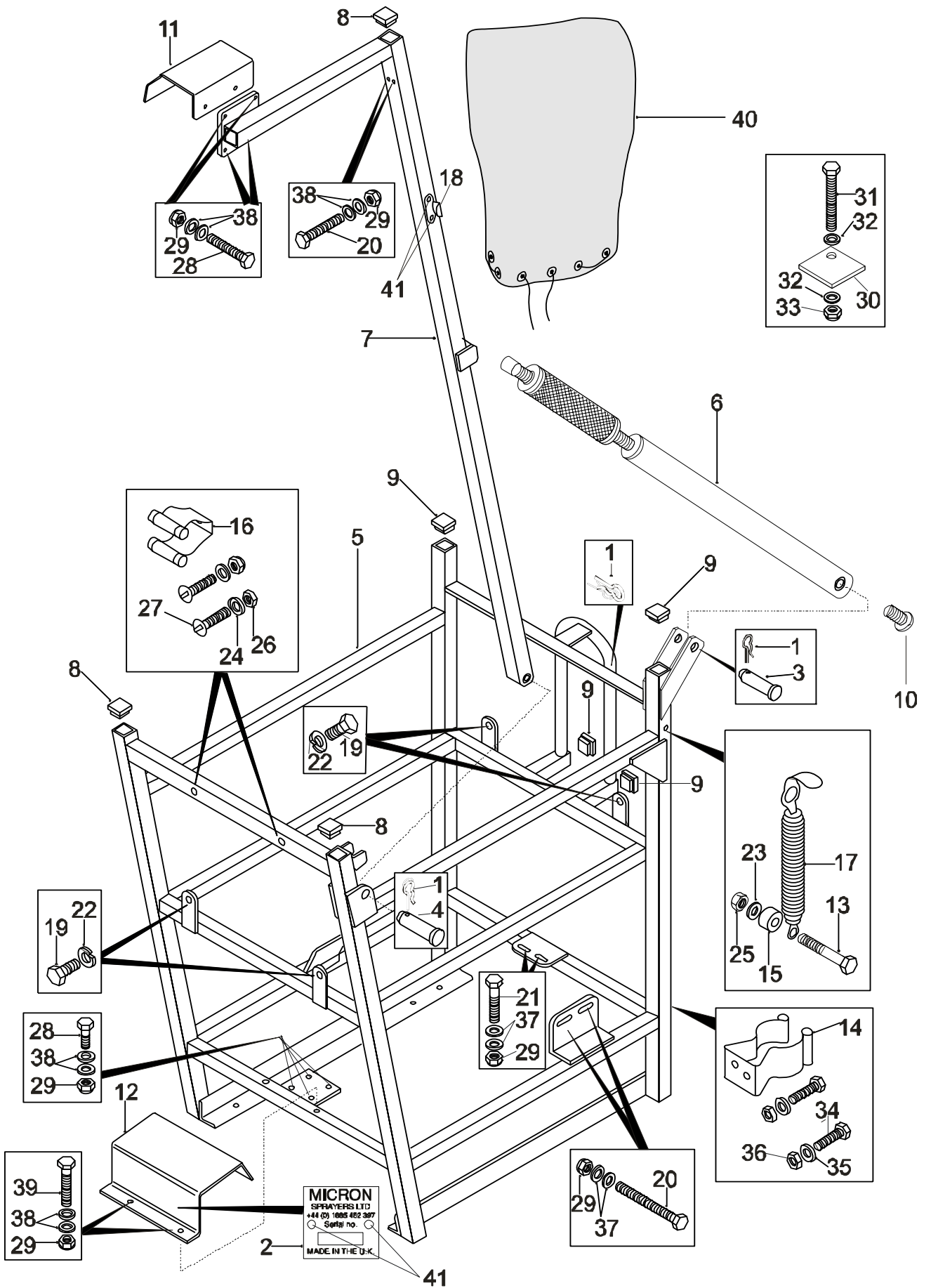

## ULVAMAST V3 FRAME PARTS LIST

ITEM NO.	DESCRIPTION	PART NO.	Qty.
1	Clip, 'R', 89.102	5671	3
2	Serial No. plate, aluminium	6316	1
3	Pivot pin, turnbuckle, mild steel - zinc plated	5889	1
4	Pivot pin, mast, mild steel - zinc plated	5890	1
5	Main frame, mild steel, nylon coated	5892	1
6	Turnbuckle	5908	1
7	Mast, mild steel, nylon coated	5911	1
8	Insert, 40 x 40 square, LDPE	5913	3
9	Insert, 30 x 30 square, LDPE	5914	4
10	Insert, Dia. 28mm, LDPE	5915	1
11	Protective cover, atomiser, mild steel - zinc plated	5921	1
12	Protective cover, pump, mild steel - zinc plated	5922	1
13	Screw, set, M10 x 60, Hex, S/S	5951	1
14	Clip, broom (to grip 35-38mm), zinc plated	5957	1
15	Spacer, od = 25.4, ld = 12.7, l = 9.53, nylon 66	5958	1
16	Clip, roller jaw (to grip 16-19mm), zinc plated	5960	2
17	Fastener, bonnet, zinc plated	5962	1
18	Anchor plate, bonnet fastener, zinc plated	5963	1
19	Bolt, M10 x 20mm, Hex, S/S	5967	4
20	Bolt, M6 x 80mm, Hex, S/S	5968	4
21	Bolt, M6 x 55mm, Hex, S/S	5969	2
22	Washer, M10, spring (rectangular section), single coil, S/S	5972	4
23	Washer, M10, flat, S/S	5973	1
24	Washer, M3, flat, S/S	5974	4
25	Nut, M10, nyloc, S/S	5975	1
26	Nut, M3, nyloc, S/S	5976	4
27	Screw, M3 x 40mm, slotted cheesehead, S/S	5977	4
28	Screw, set, M6 x 20mm, Hex, S/S	5983	8
29	Nut, M6, nyloc, S/S	5984	18
30	Plate, bolt-down, main frame, mild steel - zinc plated	5992	4
31	Screw, set, M10 x 80mm, Hex, S/S	6523	4
32	Washer, 10 x 30mm x 1.5 S/S	6527	8
33	Nut, 10mm, nyloc, S/S	5975	4
34	Bolt, M5 x 40mm, Hex, S/S	5996	2
35	Washer, M5, flat, S/S	5997	2
36	Nut, M5, nyloc, S/S	5998	2
37	Washer, 1/4", table 2 heavy, zinc plated	6001	8
38	Washer, M6, flat, form B, S/S	6017	24
39	Bolt, M6 x 45mm, Hex, S/S	6026	2
40	Cover, atomiser	AJ6412	1
41	Rivet, pop, 3mm x 12mm long, zinc plated	5651	4

# ULVAMAST V3E PLUMBING PARTS DIAGRAM

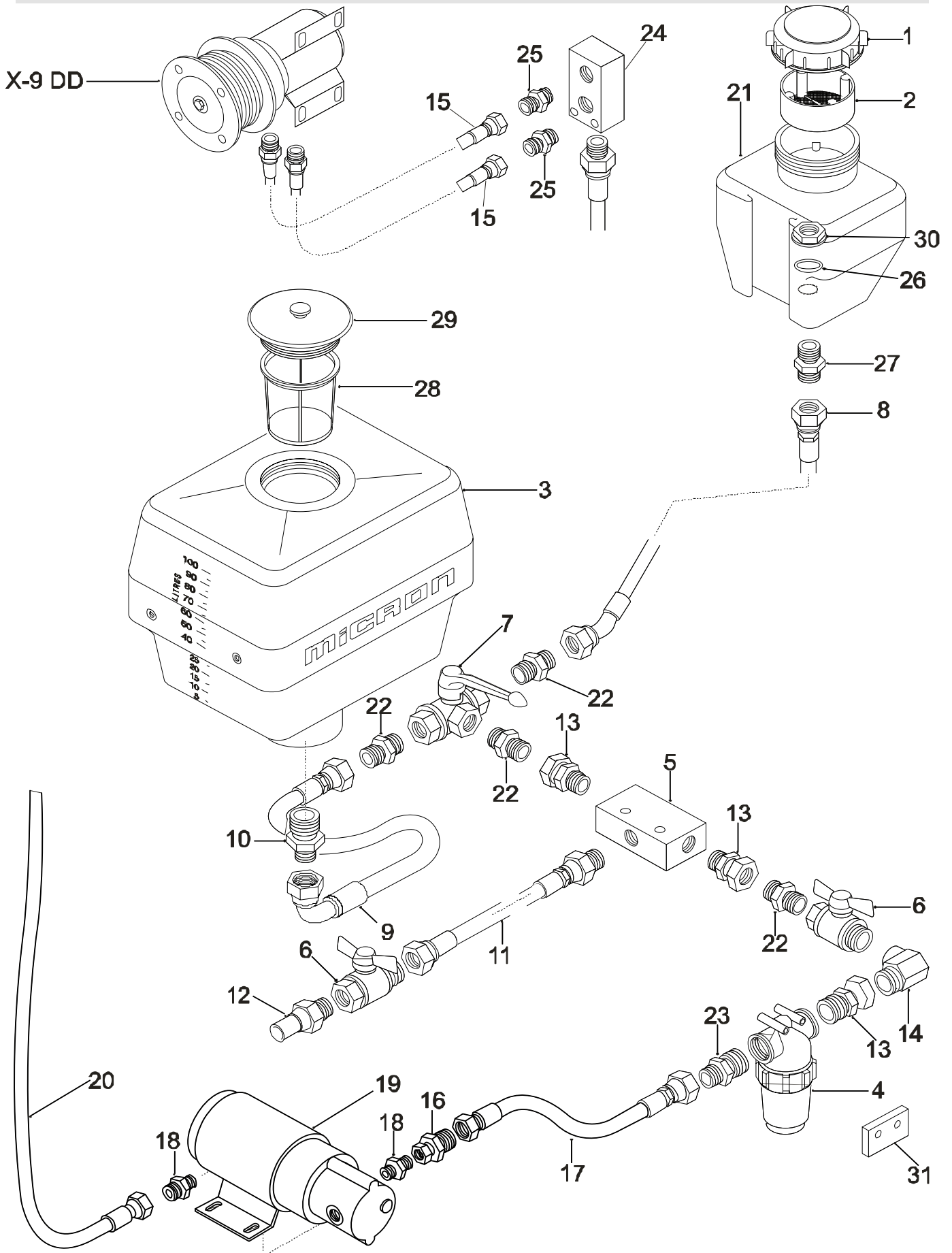

## ULVAMAST V3E PLUMBING PARTS LIST

ITEM NO	DESCRIPTION	PART NO	QTY
1	Cap assembly, backpack	5208A	1
2	Filter bowl	5449	1
3	Tank, 100 litre, HDPE - UV stabilised HDPE	5823	1
4	Filter, 1/2" BSP female, c/w viton 'O' rings	5881A	1
5	Manifold, main frame, mild steel - zinc plated	5882	1
6	Valve, 1/2" BSP male/1/2" BSP female, T-handle, brass/plated steel	5900	2
7	Valve, 1/2" BSP female, 3 way, L-handle, brass/plated steel	5901	1
8	Hose, 1/2", L = 0.39M, S/S braided PTFE lined, 135 degree swept female, 1/2"	5923	1
9	Hose, 1/2", L = 0.32M, S/S braided PTFE lined, straight female, 1/2" BSP, P/S	5931	1
10	Adaptor, 3/4" BSP male - 1/2" BSP male, P/S	7131	1
11	Hose, 1/2", L = 1.1 M, S/S braided PTFE lined, straight male, 1/2" BSP, P/S -	7127	1
12	Hosetail 3/8 - 1/2" BSP male	7128	1
13	Adaptor, 1/2" BSP male - 1/2" BSP female, P/S	7132	3
14	Elbow, 90 degree compact, 1/2" BSP, female - 1/2" BSP female, P/S	7133	1
15	Hose, 1/4", L - 0.38 M, S/S braided PTFE lined, straight male, 1/8" BSPT, P/S -	6774	2
16	Adaptor, 1/2" BSP male - 1/4" BSP female, P/S	5935	1
17	Hose, 1/2", L = 0.265 M, S/S braided PTFE lined, straight female, 1/2" BSP, P/S	5936	1
18	Adaptor, 1/4" BSP male - 1/4 NPT male, P/S	7139	2
19	Gear pump complete S/S	7140	1
20	Hose, 1/4", L = 1.7M, S/S braided PTFE lined, straight female 1/4" BSP, P/S -	5939	1
21	Tank, flushing, 10 litre, UV stabilised MDPE	5955	1
22	Adaptor, 1/2" BSP male - 1/2" BSP male, P/S	5961	4
23	Adaptor, 1/2" BSP male - 1/2" BSP male taper, P/S	7135	1
24	Manifold, mast, 1/4" BSP in - 1/4" BSP out, mild steel - zinc plated	6005	1
25	Adaptor, 1/4" BSP male - 1/4" BSP male, P/S	6777	2
26	'O' ring, BS116 viton	6721	1
27	Adaptor 1/2 x 1/2" Bsp m/m Bulkhead	7126	1
28	Filter basket strainer	AJ6200	1
29	Tank lid with air vent	AJ6201A	1
30	Nut, 1/2" BSP, flanged, brass	AJ6295	1
31	Spacer	7130	1

# ULVAMAST V3M PLUMBING PARTS DIAGRAM

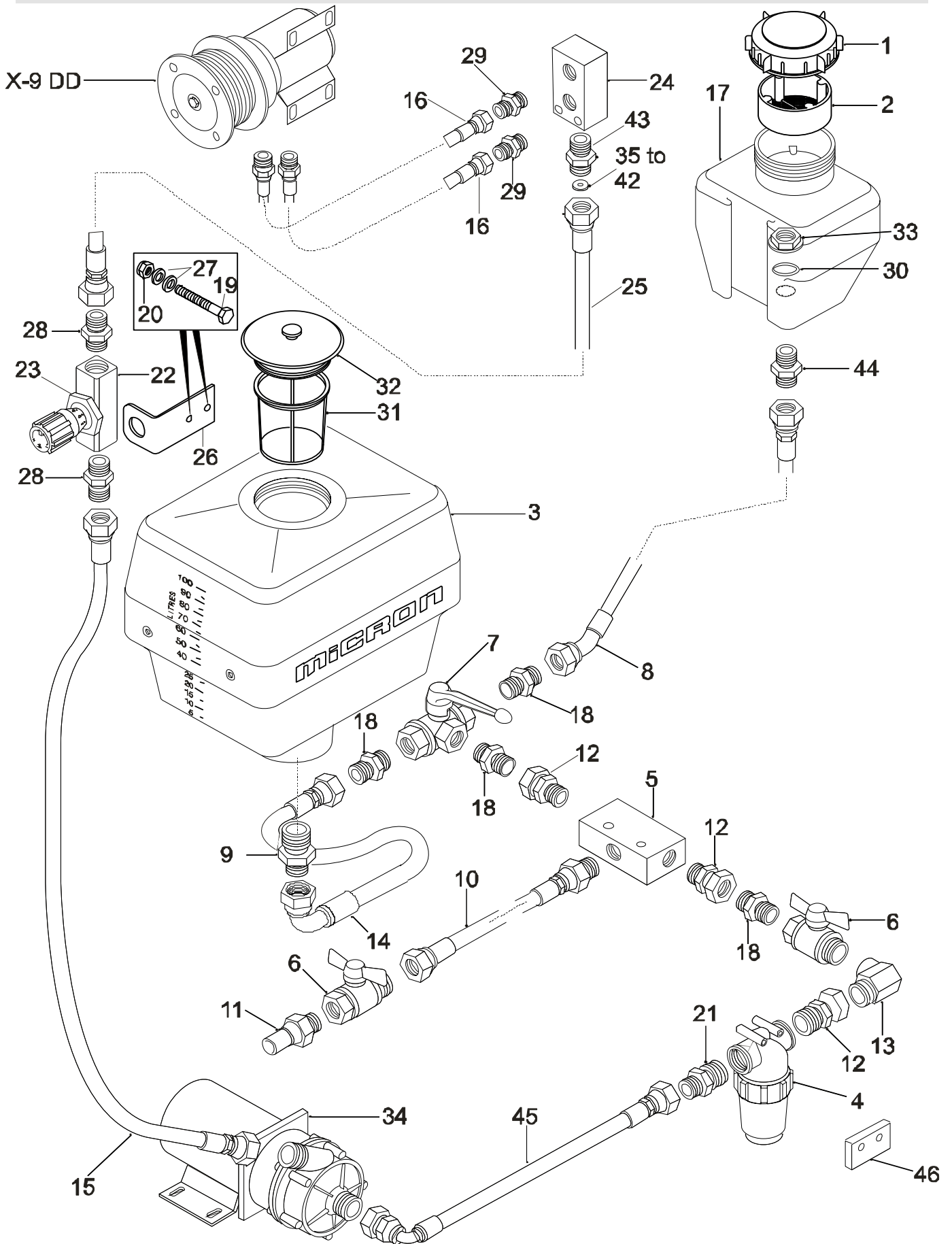

## ULVAMAST V3M PLUMBING PARTS LIST

ITEM	DESCRIPTION	PART	Qty.
1	Cap assembly, backpack	5208A	1
2	Filter bowl	5449	1
3	Tank, 100 litre, U.V. stabilised HDPE	5823	1
4	Filter, 1/2" BSP Female, c/w viton 'O' rings	5881A	1
5	Manifold, main frame, mild steel - zinc plated	5882	1
6	Valve, 1/2" BSP male / 1/2" BSP female, T-handle, brass/plated steel	5900	2
7	Valve, 1/2" BSP female, 3 way, L-handle, brass/plated steel	5901	1
8	Hose, 1/2", L = 0.39 M, S/S braided PTFE lined, 135 degree swept, female 1/2" P/S - straight female, 1/2" BSP, P/S	5923	1
9	Adaptor, 3/4" BSP male - 1/2" BSP male, P/S	7131	1
10	Hose, 1/2", L - 1.1 M, S/S braided PTFE lined, straight male, 1/2" BSP, P/S - standpipe, P/S	7127	1
11	Hosetail 3/8 - 1/2" BSP male	7128	1
12	Adaptor, 1/2" BSP male - 1/2" BSP female, P/S	7132	3
13	Elbow, 90 degree compact, 1/2" BSP, female - 1/2" BSP female, P/S	7133	1
14	Hose, 1/2", L = 0.32 M, S/S braided PTFE lined, straight female, 1/2" BSP, P/S swept female, 1/2" BSP, P/S	5931	1
15	Hose, 3/8", L = 0.49 M, S.S. braided PTFE lined, straight female, 1/2" BSP, P/S female, 3/8" BSP, P/S	5932	1
16	Hose, 1/4", L = 0.38 M, S/S braided PTFE lined, straight male, 1/4" BSPT, P/S - female, 1/8" BSP, P/S	6774	2
17	Tank, flushing, 10 litre, MDPE - UV stabilised	5955	1
18	Adaptor, 1/2" BSP male - 1/2" BSP male, P/S	5961	4
19	Bolt, M6 X 55mm, HEX, S/S	5969	2
20	Nut, M6, Nyloc, S/S	5984	2
21	Adaptor, 1/2" BSP male - 1/2" BSP male taper, P/S	7135	1
22	Valve, 1/4" BSP female, needle, brass nickle plated (viton seal)	6002	1
23	Nut, M17, HEX, panel mounting, zinc plated	6003	1
24	Manifold, mast, 1/4" BSP in - 1/4" BSP out, mild steel - zinc plated	6005	1
25	Hose, 3/8", L = 1.1 M, S/S braided PTFE lined, straight female, 3/4" GHT union, brass - straight female, 3/8" BSP, P/S	6006	1
26	Bracket, needle valve, main frame	6008	1
27	Washer, M6, flat, form B, S/S	6017	4
28	Adaptor, 3/8" BSP male - 1/4" BSP male taper, P.S.	7136	2
29	Adaptor, 1/4" BSP male - 1/4" BSP male, P/S	6777	2
30	'O' ring, BS116 viton	6721	1
31	Filter basket strainer	AJ6200	1
32	Tank lid with air vent	AJ6201A	1
33	Nut, 1/2" BSP, single chamfered, brass	6797	1
34	Pump, DC 40/10, 12 V	AJ6297	1
35	Orifice restrictor plate, No.24	AJ6337	1
36	Orifice restrictor plate, No.30	AJ6338	1
37	Orifice restrictor plate, No.39	AJ6339	1
38	Orifice restrictor plate, No.49	AJ6340	1
39	Orifice restrictor plate, No.59	AJ6341	1
40	Orifice restrictor plate, No.68	AJ6342	1
41	Orifice restrictor plate, No.80	AJ6343	1
42	Orifice restrictor plate, No.98	AJ6344	1
43	LFM body, 1/4" BSP, brass	AJ6379	1
44	Adaptor 1/2 x 1/2" Bsp m/m Bulkhead	7126	1
45	Hose, 1/2", L = 0.335M, S/S braided PTFE lined, straight female, 1/2" BSP, P/S swept female, 1/2" BSP, P/S	7134	1
46	Spacer	7130	1

## MICRON X-9 DD ATOMISER PARTS DIAGRAM

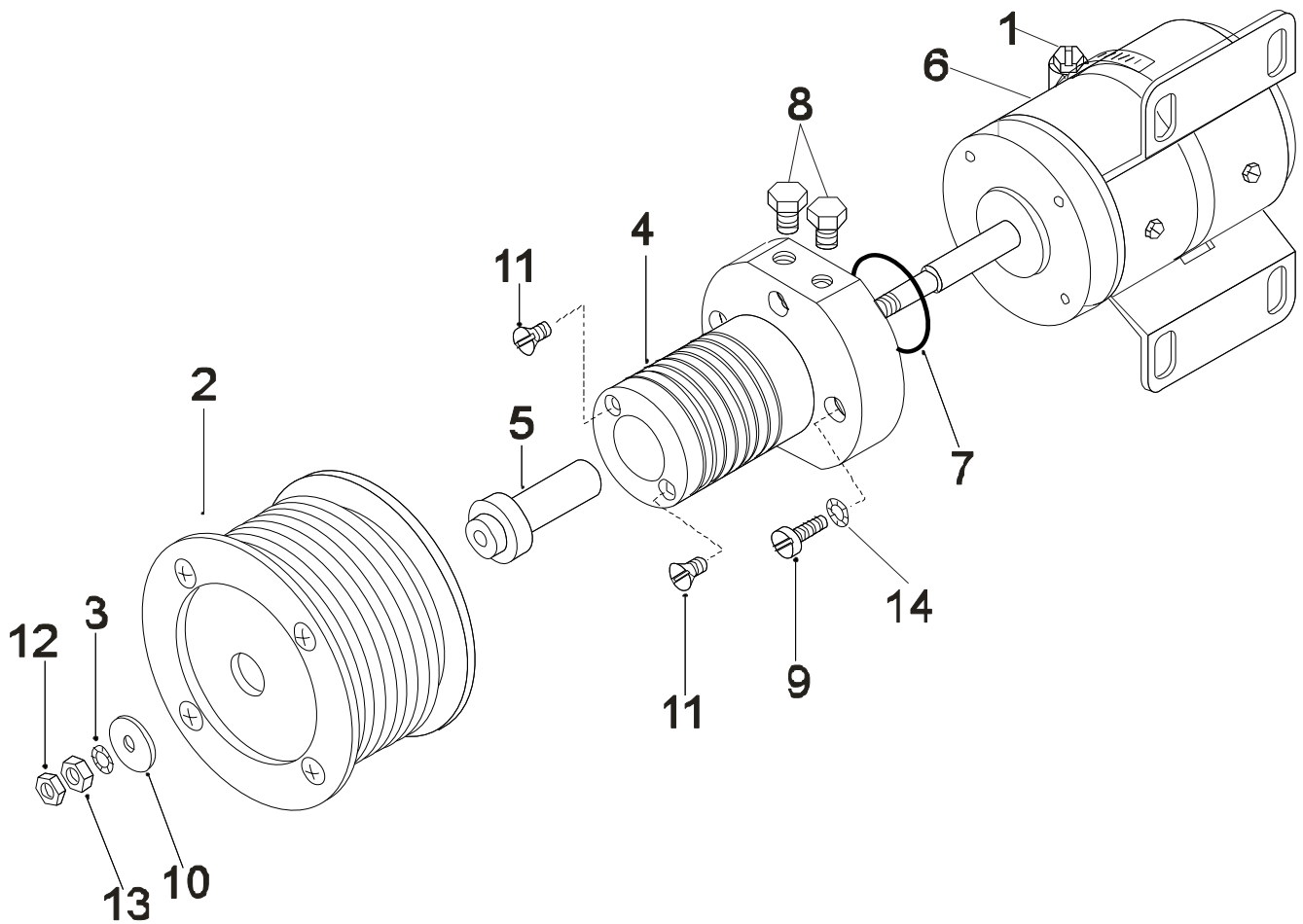

## MICRON X-9 DD ATOMISER PARTS LIST

ITEM NO.	DESCRIPTION	PART NO.	Qty.
1	Clip, 50 - 70 mm, jubilee, P/S	4086	2
2	Atomiser stack assembly	5461A	1
3	Washer, 6mm, shakeproof external, P/S	5525	1
4	Atomiser body, X9DD, black acetal	5838	1
5	Slinger, X9DD, brass	5842	1
6	Motor, 12 V, atomiser	5865	1
7	'O' ring, BS 618, viton	5867	1
8	Plug, 1/8" BSP Taper, hexagon, external, brass	7137	2
9	Screw, M5 x 20, slotted pan head, S/S	5886	4
10	Washer, M6 x 25 O/D, plain, S/S	5887	1
11	Screw, 4 BA x 1/4" long, slotted c/sunk, brass	5888	2
12	Nut, M6, half nut, S/S	5982	1
13	Nut, M6 S/S	5981	1
14	Washer, 2 BA, shakeproof, external, P/S	T5253	4

## ULVAMAST V3 FILTER (5881A) DIAGRAM

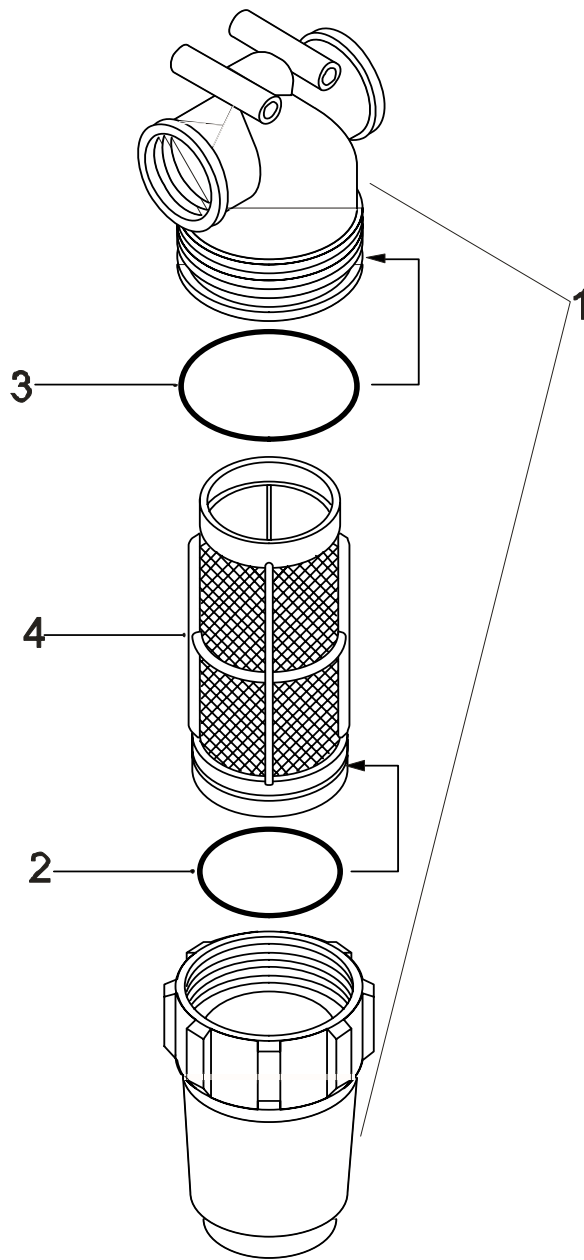

## ULVAMAST V3 FILTER (5881A) PARTS LIST

ITEM NO.	DESCRIPTION	PART NO.	Qty.
1	Filter body, 1/2" BSP female, 50 mesh, pressure line	5881	1
2	'O' ring, filter mesh, viton	5403	1
3	'O' ring, in-line filter, viton	AJ6146	1
4	Filter, in line, 50 mesh	LF5136	1

## ULVAMAST V3E PUMP (7140) DIAGRAM

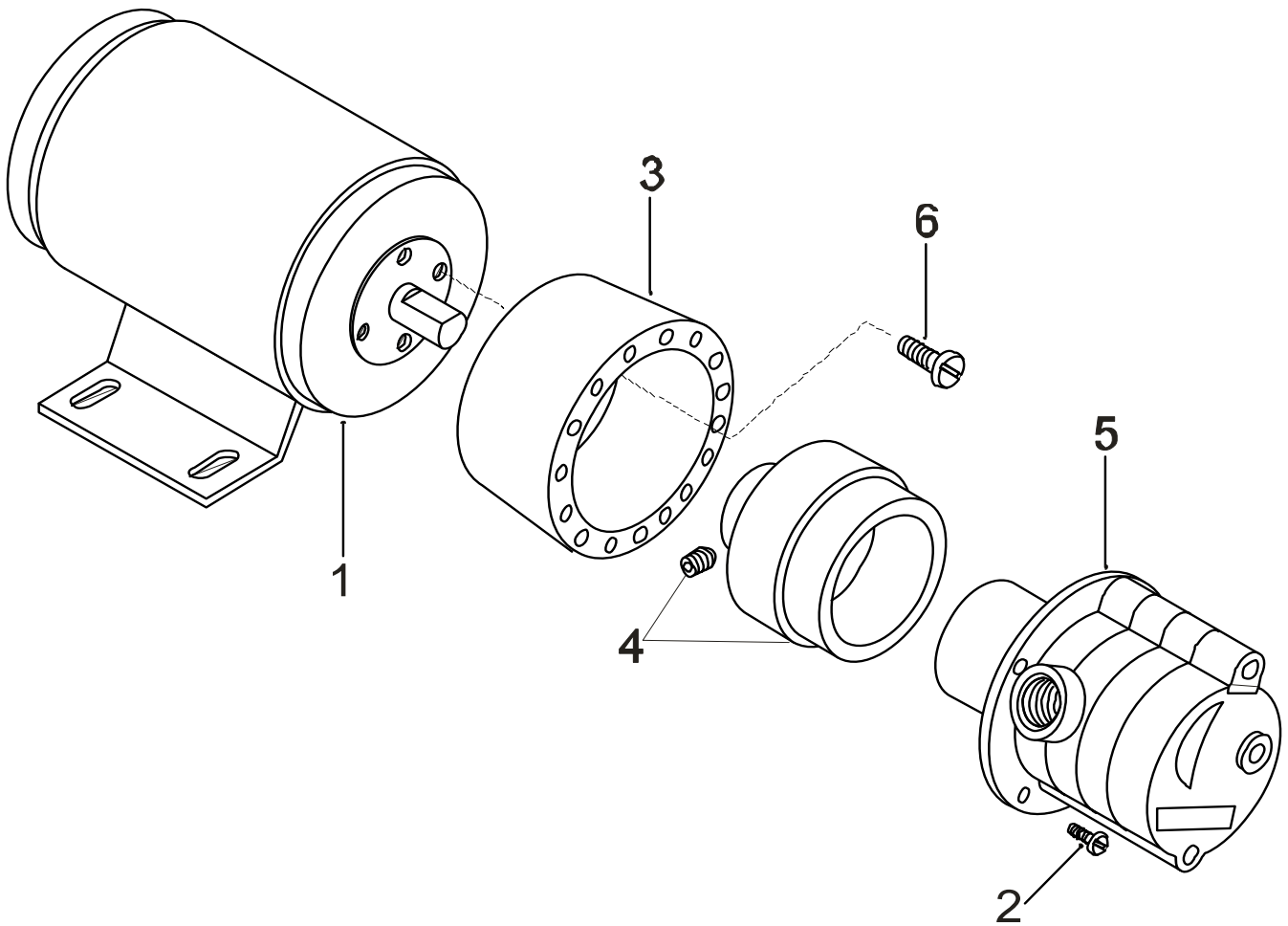

## ULVAMAST V3E PUMP (7140) PARTS LIST

ITEM	DESCRIPTION	PART	Qty.
1	Motor, 12V, gear pump	5866	1
2	Screw, No. 4 UNC x 3/8", slotted panhead, S/S	5990	4
3	Adaptor, pump/motor, gear pump	5986	1
4	Drive, magnetic, gear pump, complete with grub screw	5987	1
5	Pump head, gear pump S/S	7256	1
6	Screw, No. 8 UNC x 1/2", slotted panhead, S/S	5989	4
	Service Pack, Pump head S/S Head only	7259	1

## ULVAMAST V3M (AJ6297) PUMP DIAGRAM

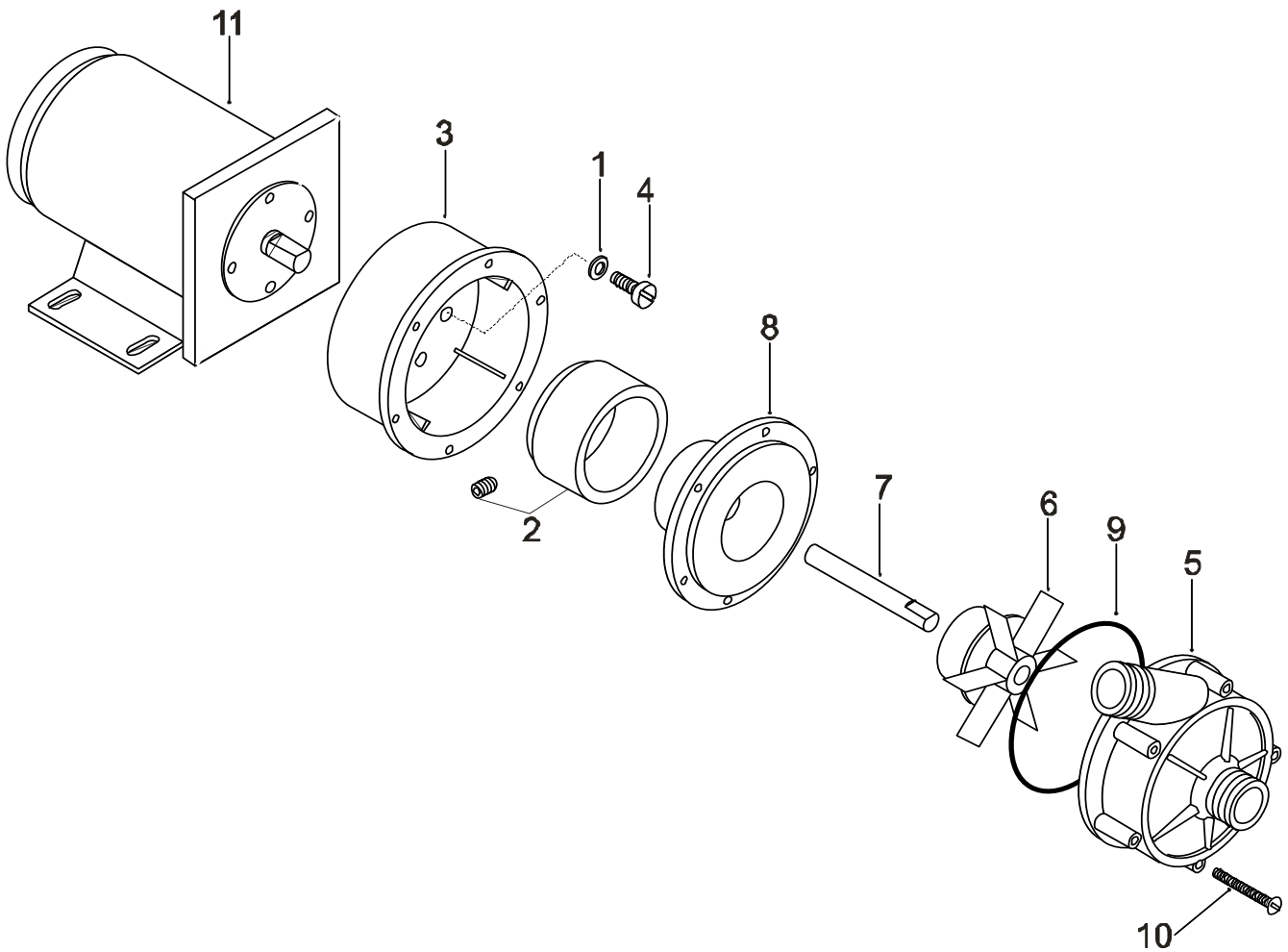

## ULVAMAST V3M PUMP (AJ6297) PARTS LIST

ITEM	DESCRIPTION	PART	Qty.
1	Washer, 2.BA shakeproof	4220	4
2	Drive magnet complete with grub screw	5766	1
3	Pump motor bracket, PP, blue	5767	1
4	Screw, M5 x 12mm, ch/head	5768	4
5	Pump body, 1/2" BSP in/out, PP	5770	1
6	Impeller, 10 pole, 37 ozins, PP	5771	1
7	Shaft, Ceramic Hilox 961	5772	1
8	Spindle housing, PC blue, PP	5773	1
9	'O' ring, 200-148, viton, black	5774	1
10	Screw, No. 6 x 1.5", pozi, S/T	5775	6
11	Motor, 12V DC dimpled	AJ6420	1

# ULVAMAST V3 ELECTRICS DIAGRAM

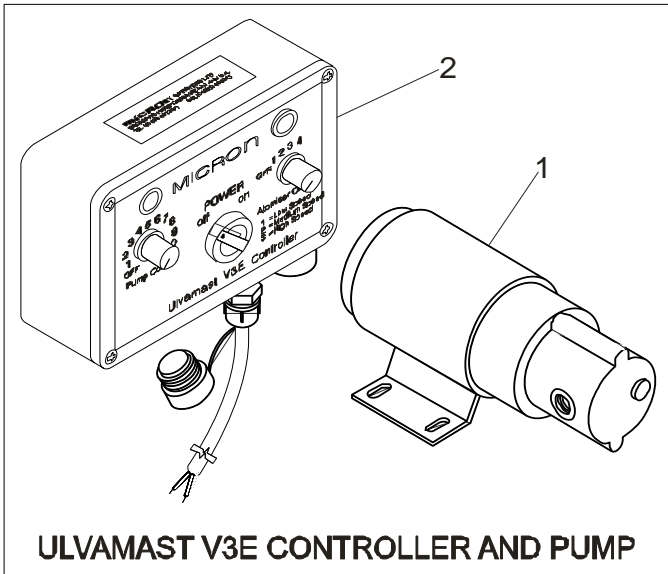

ULVAMAST V3E CONTROLLER AND PUMP

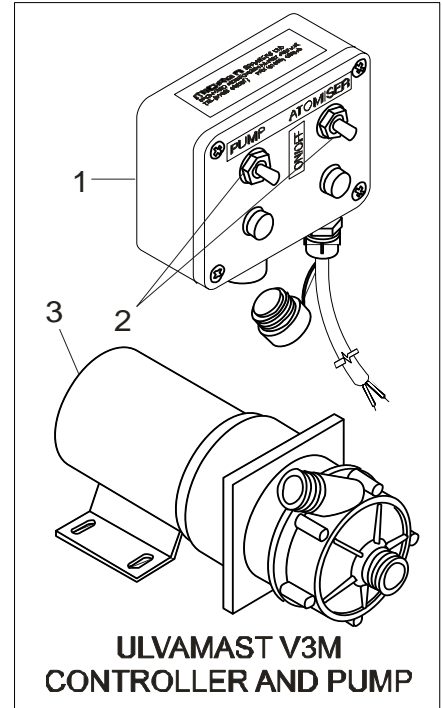

ULVAMAST V3M CONTROLLER AND PUMP

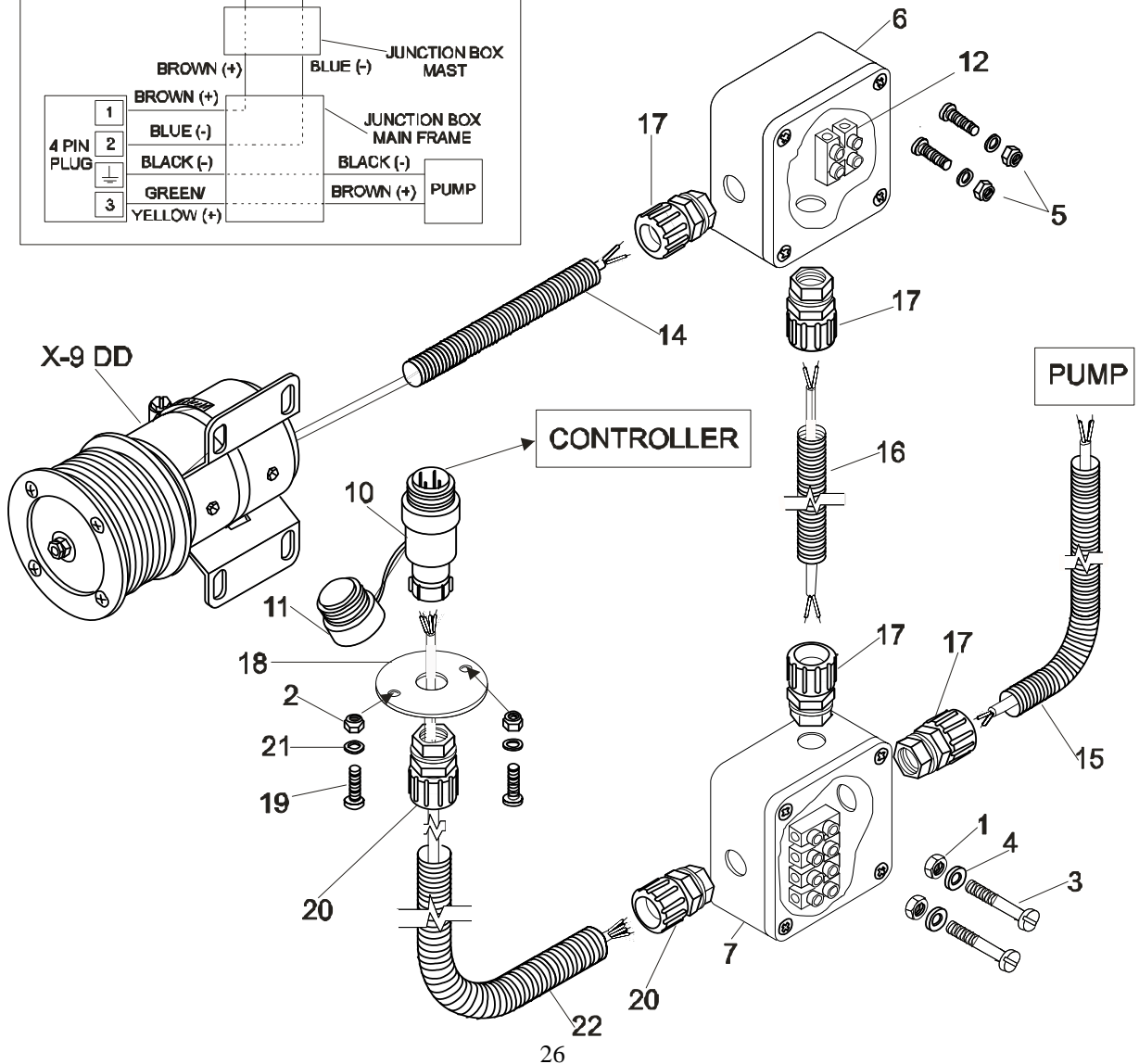
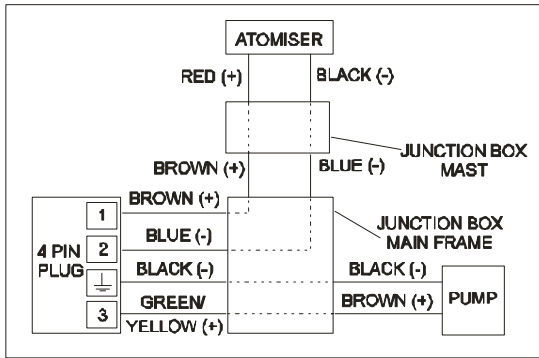

## ULVAMAST V3 ELECTRICS PARTS LIST

ITEM NO.	DESCRIPTION	PART NO.	Qty.
1	Nut, 4 BA, nyloc, zinc plated	3667	2
2	Nut, M6, nyloc, zinc plated	3691	2
3	Screw, 4 BA x 7/8", cheese head, zinc plated	4693	2
4	Washer, 4 BA, flat, zinc plated	4756	2
5	Setscrew M4 x 60 C/H S/S	6728	2
	Nut M4 Nyloc S/S	6729	2
	Washer M4 S/S	6730	2
6	Box, junction, mast, aluminium	5894	1
7	Box, junction, main frame, aluminium	5896	1
8	Cable, 1.5, L = 5 metres, 4 core, black PVC	5902/5000	1
9	Cable, 1.5, L = 2.15 metres, 2 core, black PVC	5903/2150	1
10	Plug, 4 pin	5904	1
11	Cap, protective (for 5904)	5905	1
12	Terminal block, 2, 16A, nylon 6,6	5942/2	1
13	Terminal block, 4, 16A, nylon 6,6	5942/4	1
14	Conduit, NC 16, L = 210mm, flexible nylon	5943/210	1
15	Conduit, NC 16, L = 360mm, flexible nylon	5943/360	1
16	Conduit, NC 16, L = 2 metres, flexible nylon	5943/2000	1
17	Cable gland, 16mm dia	5946	4
18	Plate, bulk head	5948	1
19	Screw, M6 x 25mm, slotted, pan head, zinc plated	5952	2
20	Cable gland, 20mm dia	5953	2
21	Washer, M6, flat, mild steel - plated	5966	2
22	Conduit, NC 21, L = 2500 mm, flexible nylon	AJ6187/250	1

## ULVAMAST V3M CONTROLLER AND PUMP

ITEM NO.	DESCRIPTION	PART NO.	Qty.
1	Box, switch, complete (with labels)	5954A	1
2	Switch, hermetically sealed	AJ6410	2
3	Pump, D.C. 40/10 12 V	AJ6297	1

## ULVAMAST V3E CONTROLLER AND PUMP

ITEM NO.	DESCRIPTION	PART NO.	Qty.
1	Pump, gear	5938	1
2	Control box (including battery cable and labels)	5945A	1

## ULVAMAST V3 TOOLKIT AND SPARE PARTS (not shown)

ITEM	DESCRIPTION	PART	Qty.
1	Spanner, 2BA x 0BA, O/E, pressed steel	4102	1
2	Spanner, 10mm x 11mm, O/E, pressed steel	4112	1
3	Washer, 6mm, shakeproof external, P/S (atomiser)	5525	1
4	Vibratak, high speed	5736	1
5	Plug, 1/8" BSPT, hexagon, external, brass	7137	1
6	Washer, M6 x 25 O/D, plain, S/S (atomiser)	5887	1
7	Screw, 4 BA x 1/4" long, slotted C/sunk, brass (atomiser)	5888	2
8	Terminal block, 4, 16A, Nylon 6,6	5942/4	1
9	Bolt, M10 x 20, HEX, S/S	5967	2
10	Screw, set, M6 x 25mm, HEX, S/S	5983	4
11	Nut, M6, half nut, S/S (atomiser)	5981	1
12	Nut, M6, S/S (atomiser)	5982	1
13	Nut, M6, nyloc, S/S	5984	10
14	Tape, PTFE	6014	1
15	Screwdriver / wire stripper	6015	1
16	Tie, cable (medium)	6018	2
17	Bolt, M6 x 90mm, HEX, S/S	6024	2
18	'O' ring, in-line filter	AJ6146	2
19	'O' ring, filter mesh	5403	2
20	Spanner, 10", adjustable	AJ6357	2
21	Reversible screwdriver, 6mm x No.2	AJ6360	1
22	Roll, tool, 12 pocket	AJ6363	1
23	Tie, cable (small)	AJ6418	4
24	Measuring jug, 1 litre	LF2177	1

### Ulvamast V3E Additional Spare Parts

ITEM NO.	DESCRIPTION	PART NO.	Qty.
1	Key, allen, 3/32" A/F	4105	1
2	Fuse, 10 amp, (red)	6788	1
3	Fuse, 20 amp, (Yellow)	7195	1

### Ulvamast V3M Additional Spare Parts

ITEM NO.	DESCRIPTION	PART NO.	Qty.
1	Key, allen, 1/16" A/F	6013	1
2	Fuse, 10 amp, (red)	6788	1
3	Fuse, 20 amp, (Yellow)	7195	1

## USEFUL REFERENCES



1. The Desert Locust Guidelines  
Section IV. Control  
Food and Agriculture Organisation of United Nations, Rome. 1992.
2. Locust Handbook (3rd edition)  
Editor: Steedman, A. 1990  
Natural Resources Institute, London, UK ISBN 0-85954-281-5
3. Precis de lutte Antiacridienne, Les Pulverisations d'insecticides  
Tahar Rachadi  
CIRARD/PRIFAS, Montpellier, France 1991.
4. A Guide to Migrant Pest Management in Africa  
Editor: Meinzingen, W.F.  
Food and Agriculture Organisation of United Nations, Rome, Italy. 1993.  
ISBN 92-5-103339-0.
5. Workshop on Spray Equipment used in Desert Locust Control, 21st - 23rd August 1994. FAO  
Commission for Controlling the Desert Locust in the Near East, Cairo, Egypt.
6. Controlling Desert Locust Nymphs with Bendiocarb applied by a vehicle mounted spinning-disc  
sprayer.  
P.M. Symmons, C. J. Boase, J.S. Clayton and M. Gorta.  
Crop Protection, Vol 8. 1989.

## DECLARATION OF CONFORMITY

93/44/EEC

Name of manufacturer or supplier:	Micron Sprayers Limited
Full postal address:	Bromyard Industrial Estate, BROMYARD, Herefordshire.
Country of Origin:	England
Post Code:	HR7 4HS
Description of Product:	Vehicle mounted ULV sprayer
Name and model number of machine:	Ulvamast V3M and E models
Place of Issue:	Bromyard, England.
Name of authorised Representative:	J. S. Clayton
Position of authorised Representative:	Technical Director

### DECLARATION:

I declare that, as the authorised Representative, the above information in relation to the supply/manufacture of this product is in conformity with the requirements of the 93/44/EEC Machinery Directive the EMC Directive 89/336/EEC and complies with the relevant essential health and safety requirements.

Signature of authorised Representative - \_\_\_\_\_

