

A PORTABLE MOTORISED AXIAL FAN AIR-ASSISTED CDA SPRAYER: A NEW APPROACH TO INSECT AND DISEASE CONTROL IN COFFEE

G S POVEY, J S CLAYTON, T E BALS

Micron Sprayers Limited, Three Mills, Bromyard, Herefordshire, HR7 4HU, UK

ABSTRACT

A portable motorised air assisted CDA sprayer (the 'Motax') has been developed as the result of an extensive collaborative research project between the National Coffee Growers Federation of Colombia and the UK Overseas Development Administration, involving UK manufacturers Micron Sprayers Ltd. The objective of the project was to improve manual spray application methods in Colombian coffee for the control of coffee leaf rust. However, the sprayer is now also being considered for control of coffee berry borer, which has become a major problem in Colombia. The sprayer uses a rotary atomiser to produce uniformly-sized droplets which are propelled by a wide and turbulent air blast away from the operator, improving operator safety. Compared with traditional high volume techniques the sprayer offers the possibility of improved spray coverage and penetration at low total volumes of application, typically 30-70 litres/ha, allowing more timely spray treatments with the potential to adopt more responsive integrated insect pest and disease management strategies.

INTRODUCTION

Coffee leaf rust (*Hemileia vastatrix*) first reached Colombia in 1983 and was regarded as a major threat to Colombia's economy. Until then, Colombian coffee had been virtually free from insect pests and diseases, with no routine spraying of insecticides or fungicides. To combat the threat of coffee leaf rust, traditional high volume spraying techniques were initially introduced. These high volume techniques used pre-pressurised knapsack sprayers or semi-stationary pumps connected by long trailing hoses to lances fitted with hydraulic pressure nozzles. In both cases, total volume application rates of the commonly used copper-based fungicide formulations were in the range 200-500 litres/ha. Under Colombian conditions (dense planting of up to 10,000 plants/ha and steep slopes) the work rate was often as low as 0.2 ha/man/day, making the timely application of fungicides almost impossible.

It was against this background that a project was undertaken between the National Federation of Colombian Coffee Growers (FNCC) and the UK Overseas Development Administration (ODA), the objective of which was to develop appropriate portable low volume spraying equipment for coffee spraying in Colombia (Fernandez *et al.*, 1986). The programme involved UK consultants T.L.Wiles and Associates and spray equipment manufacturers Micron Sprayers Ltd.

Initially, the project examined both low volume techniques (30-50 litres/ha) and ultra-low volume techniques (5 litres/ha) combined with the use of electrostatics to improve underleaf coverage (Sharp *et al.*, 1986). All the prototype machines used rotary atomiser technology to achieve Controlled Droplet Application (CDA) i.e. narrow droplet size spectra.

The project investigated the distribution of spray droplets through the coffee bush and considered the effects of droplet size and number, formulation, air velocity and air-beam width and the influence of electrostatic charging of spray droplets. Of particular importance were the air-flow characteristics (Sharp *et al.*, 1988). Droplet distribution data from field trials and the results of bio-assay work allowed prototype machines to be assessed in terms of efficacy for disease control (Aston *et al.*, 1991).

Extensive field testing for efficacy against coffee leaf rust was undertaken with the prototype machine using a moderate velocity turbulent air-beam to carry the spray droplets into the crop foliage. This confirmed that the prototype machine was capable of applying sufficient quantities of copper (at reduced copper dosages compared to those used with traditional high volume sprayers) to control coffee leaf rust at a total application volume of only 50 litres/ha (Waller *et al.*, 1994). Operator contamination trials were undertaken during the project which clearly demonstrated the potential for improved operator safety with the low volume system.

During the project it became apparent that the threat from coffee leaf rust was not as severe as initially feared, particularly with the introduction of the resistant variety, 'Colombia'. However, coffee berry borer (*Hypothenemus hampei*), which poses a more significant and direct threat to coffee yields, was then reported in Colombia. The need to treat areas rapidly for control of coffee berry borer highlighted the need for application techniques with a high work rate and the potential use of insecticides by farmers against this insect pest meant that operator safety became a significant issue.

Further trials took place in the period 1992-1996, aimed at the continued development and validation of the machine, and confirmation of the acceptability of the spraying technique, in actual field operations. Micron Sprayers have redesigned the prototype machine in the light of field experience gained during the trials to make a production version, the 'Motax', and this paper describes these modifications.

DESCRIPTION OF THE MACHINE (FIGURE 1)

In addition to the key application criteria of atomiser design and air-flow characteristics the development of the sprayer has addressed the problems faced by spray operators working on steep (often slippery) slopes which require the operator to have one free hand for safety. The increased work rate possible with this sprayer has meant that it had to be designed to enable operators to use the sprayer over reasonably long periods of time without suffering discomfort. The critical design criteria considered were therefore the weight distribution, minimisation of vibration, and other ergonomic requirements e.g. position of controls.

Mounting the sprayer on the operator's back ensures easy passage through the crop. As the centre of gravity is kept close to the operator, using wide shoulder straps and a waist band to

ensure good weight distribution, the sprayer can be carried without undue fatigue in normal operation. The other significant advantage of back mounting is operator safety as the operator is walking away from the spray emitted.

Deposition trials had shown that the best spray coverage was achieved by angling the air-beam into the row. It is possible to spray both sides of an inter-row with one spray pass by oscillating the air-beam from side to side. The engine/fan/atomiser unit is mounted in a light-weight cradle which is oscillated by a manually-operated handle. Throttle and spray flow valve controls are mounted on the sprayer and are easily accessible. The vertical (pitch) orientation of the engine/ fan/atomiser unit can be altered according to the crop and slope characteristics (without removing the sprayer from the operator's back).

For reasons of simplicity, spray liquid is fed to the rotary atomiser by gravity. The spray tank size has been selected to match the fuel tank capacity so that fuel and spray liquid will require refilling at the same time, thus minimising downtime or the possibility of the operator continuing to run the sprayer when the spray tank is empty.

Figure 1. Diagram of the production sprayer.

Specification of production sprayer

Weight: empty	10kg
ready to spray	18kg
Power source	33cc, 2 stroke engine
Fuel consumption	0.75 litres/h
Fan/Atomiser speed	6,500 rev/min
Airflow: speed	25m/s at fan
volume	0.8 m ³ /s
throw	up to 8m
Flowrate range	50 - 300 ml/min
Droplet size range	80 - 120 µm VMD

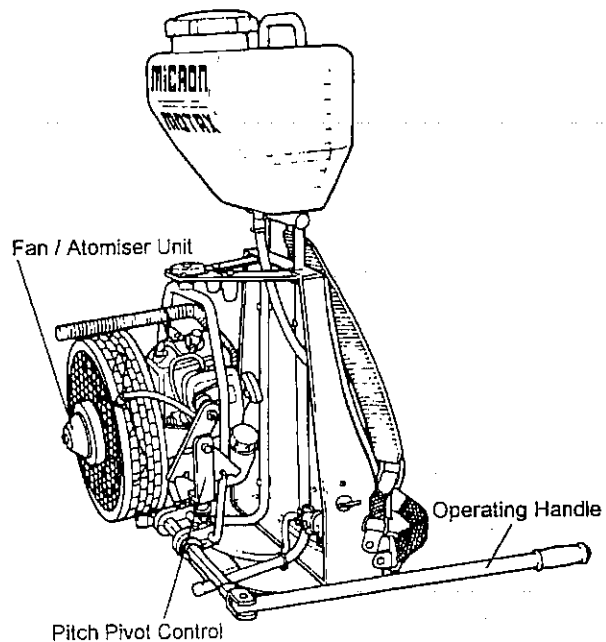

OPERATOR SAFETY

Field trials to examine the level of operator contamination showed that, under a wide range of conditions, the air-assisted CDA sprayer greatly reduced levels of operator contamination compared with traditional high volume lever operated and pre-pressurised knapsack sprayers (PPRs) with a single hand lance (see Figure 2). It also became apparent that the majority of operator contamination from high volume applications occurred due to indirect transfer of spray as the operator walks through treated foliage. The backward-facing design of the air-assisted CDA sprayer ensures that the operator does not walk through treated foliage, thereby significantly reducing potential operator contamination.

Figure 2 Comparison of the potential dermal exposure to pesticides from alternative application techniques.

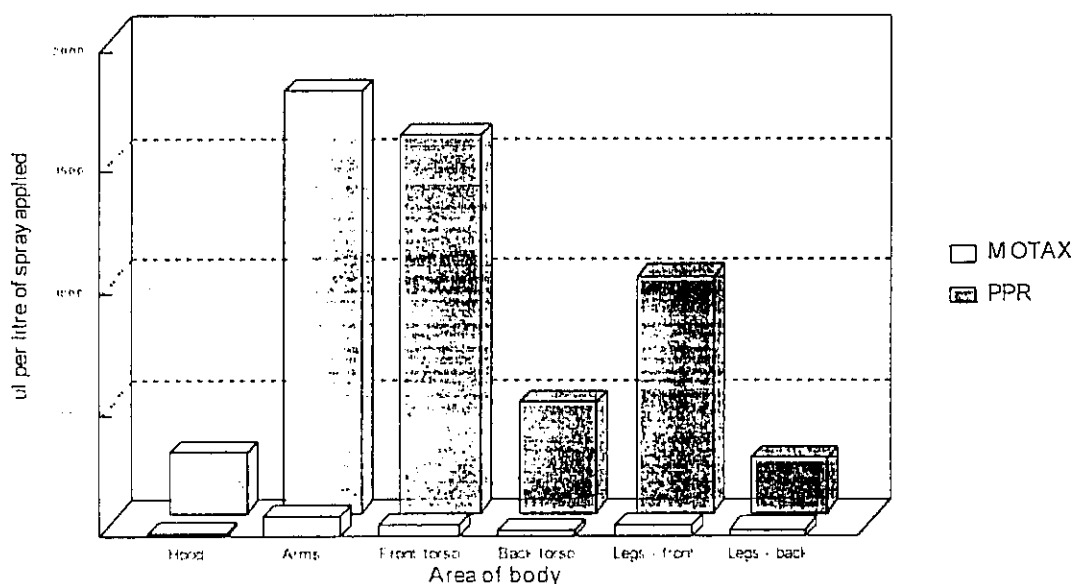

Apart from the inherent improvement in operator protection afforded by not walking through treated foliage, there are other specific safety features built into the sprayer. The tank filling aperture is of sufficiently large diameter to allow filling without spillage, the tank neck contains a filter which is deep and vented to suppress the tendency for splash back, and, very importantly, the tank cap has a seal and venting valve to prevent liquid leaking if the operator bends over. The sprayer also accommodates a safety 'cut out' switch in the end of the oscillation handle to stop the engine quickly if required.

BIOLOGICAL EFFICACY

Field trial results with the air-assisted CDA sprayer using copper oxychloride confirmed that at total application volumes of 50 litres/ha, using droplet sizes of around 100µm, good control of leaf rust was achieved - with good coverage of foliage, with laboratory trials showing that at 30 litres/ha the threshold for 100% inhibition of coffee leaf rust by copper oxychloride is 30-35 droplets/cm². Field trials were also undertaken comparing the sprayer with the standard PPR used in Colombia. Both machines applied copper oxychloride at a rate equivalent to 1.5 kg/ha, the air-assisted CDA sprayer at 50 l/ha and the PPR at 250 litres/ha, in coffee already heavily infected with leaf rust. Five applications of copper oxychloride were made at 30 day intervals and four applications at 45 day intervals. An untreated plot was included as the control. Results showed that the low volume treatments using the air-assisted CDA sprayer were at least as effective as the high volume PPR treatments (whether control was measured as the number of healthy leaves present or as a percentage of rusted leaves) and more effective at 30 day spray intervals (for which the higher work-rate

capability of the CDA sprayer is critical). A further trial demonstrated that the CDA sprayer was at least as effective as the PPR at preventing the further development of leaf rust at low disease levels (Figures 3 and 4).

Figure 3. The effect of spray treatment on the proportion of leaves showing rust infection (from Waller et al. 1994)

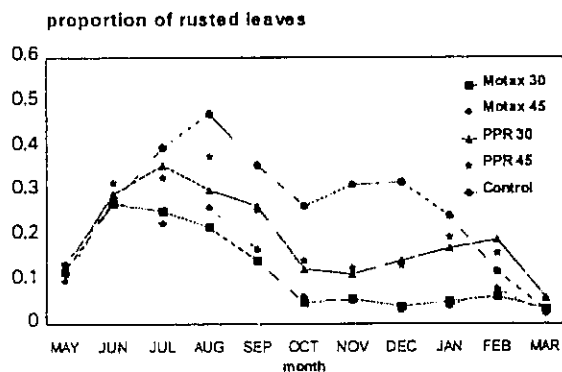
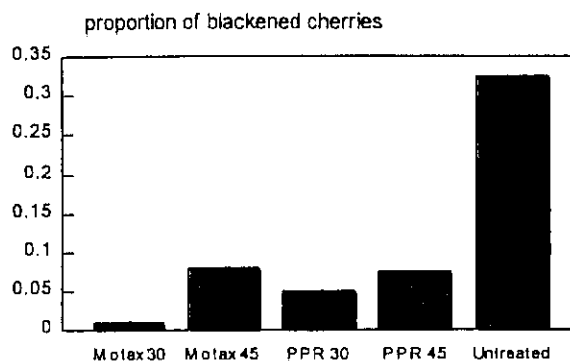

Figure 4. The effect of spray treatment on proportion of blackened coffee cherries (from Waller et al. 1994)



IMPLICATIONS OF LOW VOLUME APPLICATION METHODS FOR MANUAL SPRAY PROGRAMS

Low volume application with the air-assisted CDA sprayer offers the prospect of a five-fold improvement in work-rate compared with traditional high volume spraying techniques - from 0.2 ha/man/day to 1.0 ha/man/day or higher. Labour cost savings alone (based on the Colombian minimum wage) are over US\$20 per hectare per application. For coffee leaf rust control, for which at least four spray treatments per year are required, the labour savings would be over US\$80 per sprayed hectare. However, not only does a high work rate lead to reduced application costs but it can ensure sprays are applied at the correct time - thus allowing usage of agrochemicals to be minimised (with substantial consequential cost savings). The ability to spray rapidly may be of critical importance in coffee berry borer control programmes, where large areas need to be treated quickly and many insecticides show no significant residual effect after 15 days (Villalba *et al.*, 1995). Minimisation of agrochemical usage and improved spray targeting are pre-requisites for the use of agrochemicals within Integrated Pest Management (IPM) programmes.

CONCLUSIONS

The 'Motax' is the result of an extensive research project on optimising manual spray application in Colombian coffee. This portable air-assisted CDA sprayer offers the significant benefits of increased work rate, improved spray penetration and coverage and potential reductions in operator and environmental contamination compared with traditional high volume techniques. It offers the prospect of implementing IPM programmes with reduced use of pesticides, better spray targeting, improved operator safety and less off-target environmental contamination.

The sprayer has undergone extensive field validation trials, and has now been production-engineered to offer a robust and practical tool for farmers. Although commercialisation of the sprayer is being undertaken for coffee in Colombia, the air-flow and operator safety characteristics inherent in its design offer an advanced low volume alternative to the traditional high volume techniques currently used world-wide on many bush and vine crops.

ACKNOWLEDGEMENTS

The authors are grateful for the continued co-operation of the Federation National de Cafe Colombia (FNCC) - particularly staff at the Cenecafe research station, Dr O.Cadena, Mr D G Villalba and Dr J Leguizamon; T Wiles and Associates, Chichester UK, who successfully managed the project over a number of years; and the UK Overseas Development Administration who funded the project.

REFERENCES

- Aston, R P; Sharp, D G; Clayton, J S (1991) 'The use of air assisted hand held ULV spraying for control of coffee leaf rust in Colombia'. BCPC Monograph No. 46 'Air assisted spraying in crop protection', pp. 151-160.
- Fernandez, B; Waller, J M; Cookman, G P (1986) 'Coffee leaf rust (*Hemileia vastatrix*) in Colombia. Part I. An integrated approach to the development of machinery for the application of fungicides'. Proc. British Crop Protection Conference - Pests and Diseases, pp. 377-383.
- Sharp, D G; Bals, E J; Villalba, D (1986) 'Coffee leaf rust in Colombia. Part II. Low volume application - droplet deposition and the implications for machine design'. Proc. British Crop Protection Conference - Pests and Diseases, pp. 385-392.
- Sharp, D G; Cookman, G P; Villalba, D (1988) 'Factors influencing the deposition of droplets on coffee bushes'. Proc. Symposium international sur les techniques d'application des produits phytosanitaires', pp. 417-424.
- Villalba, D A; Bustillo A E; Chaves B (1995) 'Evaluación de insecticidas para el control de la broca del café en Colombia'. Cenicafe (Colombia) 46(3), pp 152-163.
- Waller, J M; Leguizamon, J; Gill, L F; Aston, R A; Cookman, G P; Sharp, D S; Ford, M G; Salt, D W (1994) 'Laboratory and field development of a CDA spraying system for control of coffee leaf rust (*Hemileia vastatrix*): an overview'. 'BCPC Monograph No.59 'Comparing glasshouse and field pesticide performance', pp. 261-266.