

Description.....	1
Safety .....	2
Operator protection.....	3
Preparing for spraying .....	4
Mixing, filling and calibration .....	5
Before spraying for the first time.....	7
To start spraying .....	9
To stop spraying .....	10
After spraying .....	10
Troubleshooting.....	11
Parts List Sprayhead .....	13
Parts List Atomiser .....	14
Parts List Powerpack .....	15
Parts List Backpack .....	16

**DESCRIPTION**

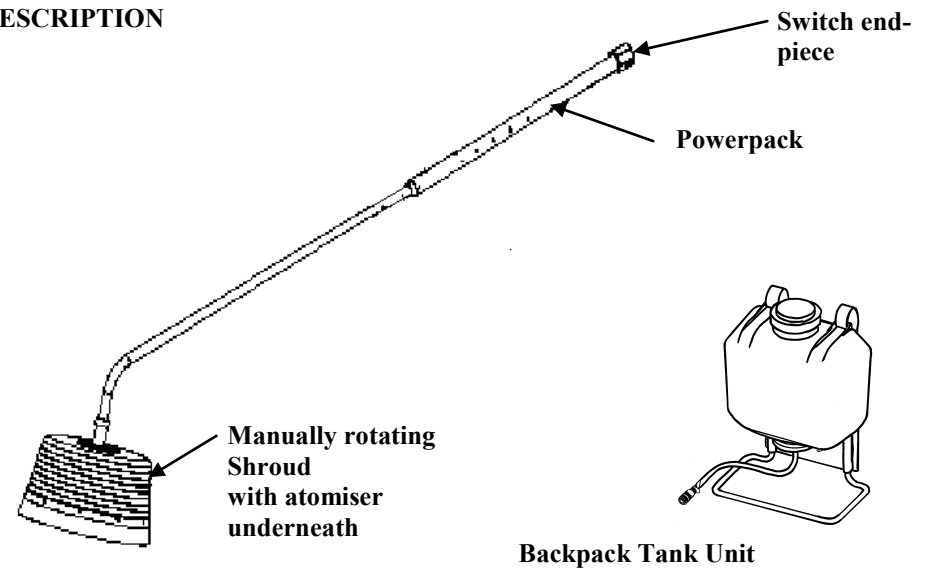

The HANDYDOME is a hand-held, shrouded, spinning disc, Controlled Droplet Application (CDA) sprayer. The HANDYDOME is powered by four ‘torch’ type batteries (D-cell/R20), with one set of good quality batteries giving around 40 hours spraying time. It is designed to apply herbicides, within a manually rotating, 35cm diameter shroud, at volumes of around 50 litres/hectare. An electric motor spins the atomiser disc to produce spray droplets. Liquid is fed by gravity, through a colour coded (yellow) feed nozzle.

**Description continued.**

The HANDYDOME can be used to apply herbicides around and right up to trees, shrubs, buildings, fence lines, borders and pathways as well as for treatment between crop rows. The un-laden weight of the machine, complete with 10 litre backpack, is 6.2 kg.

By covering the spray with a soft rotating dome to prevent the risk of spray drift, the HANDYDOME fully protects any adjacent crop as well as the environment at large.

**SAFETY**

Using agrochemicals is a hazardous process. Operators should comply with all relevant legislation and/or regulations governing the use of agrochemicals and should use appropriate personal protective equipment (see 'OPERATOR PROTECTION'). **Never** use the HANDYDOME in potentially explosive atmospheres or spray flammable liquid through it.

**Always** read the product label carefully to determine:-

- ◆ approved applications
- ◆ maximum dose rates
- ◆ maximum number of treatments
- ◆ operator protection required
- ◆ necessary environmental protection measures

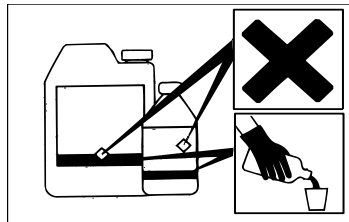

N.B. 'Dose rate' refers to the amount of chemical product applied per hectare.

**Never** eat, drink, or smoke when working with agrochemicals. After using agrochemicals or handling equipment wash your hands thoroughly. Keep people (especially children) and animals out of areas being sprayed.

**Always** store agrochemicals safely to protect people and animals, and to safeguard the environment (take special care to avoid water pollution). See spraying sections for guidelines on safe use of the HANDYDOME in operation.

## NOTES

## OPERATOR PROTECTION

**Always** wear the protective clothing items listed on the product label for mixing and filling. The **minimum** protective clothing required for **spraying** with the HANDYDOME is:

- ◆ rubber gloves and boots
- ◆ boots/shoes and long trousers
- ◆ eye protection
- ◆ long sleeved shirt



### Note:

- a) Acoustic information: the sound pressure level at the operator's ear does not exceed 70 dB(A).
- b) Vibration: the weighted RMS acceleration value at the hands when using this machine does not exceed 2.5 m/sec<sup>2</sup>.

## PREPARING FOR SPRAYING

The sprayer is delivered as 3 sub-assembled units;

- (a) The HANDYDOME sprayhead and handle unit.
- (b) The Powerpack unit incorporating the switch.
- (c) The backpack tank unit.

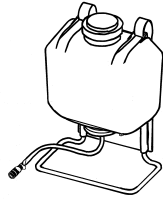
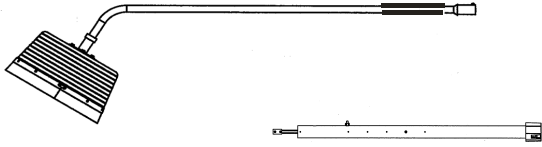

### To Assemble the HANDYDOME Sprayer

Fit the HANDYDOME sprayhead and handle unit to the Powerpack by first pushing the electrical plug on the powerpack (1) into the socket on the sprayhead and handle unit (2). Then depress the white button (3) on the sprayhead and handle unit whilst pushing it into the Powerpack until the button locates in the hole provided (4).

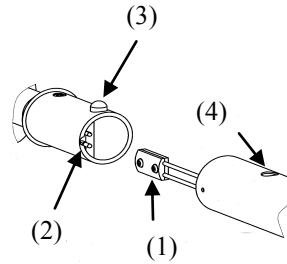

Remove the switch end piece as follows; push in and turn, as shown (A), then pull off, as shown (B).

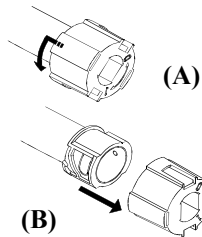

Insert four batteries (D-cell/R20), flat end (negative) first, replace the switch end piece.

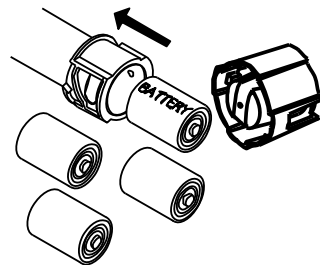

Name of manufacturer or supplier:

Micron Sprayers Ltd.

Full postal address:

Bromyard Industrial Estate,  
BROMYARD, Herefordshire

Country of origin:

England

Post code:

HR7 4HS

Description of Product:

Battery powered, hand-held  
agricultural spraying machine.

Name and model number of machine:

HANDYDOME

Place of Issue:

Bromyard, England

Name of authorised representative:

G. S. Povey

Position of authorised Representative:

Joint Managing Director

## DECLARATION OF CONFORMITY

### DECLARATION:

I declare that as the authorised Representative, the above information in relation to the supply/manufacture of this product is in conformity with the requirements of the Machinery Directive 2006/42/EC and complies with the relevant essential health and safety requirements.

Signature of authorised Representative:

## 10L BACKPACK TANK UNIT, PARTS LIST AND DIAGRAM.

ITEM	QTY	PART NO.	DESCRIPTION	ITEM	QTY	PART NO.	DESCRIPTION
1	1	5207	BACKPACK, 10 LITRE	10	1	5778	HOSE CONNECTOR 6mm
2	1	5208A	CAP	11	1	5779	UNION NUT
3	2	4915	SCREW M5 x16mm	12	1	5956	SCREW M5 x 12 POZI
4	2	5863	SCREW M5 x 50	13	1	5780	VALVE CLAMP
5	1	5206	FRAME	14	1	6028	CLIP, HOSE WIRE 9.1mm
6	1	5600	ELBOW 1/4" BSP x 8mm	15	1	LF4454	RESTRICTOR WHITE/BLUE
7	1	6029	CLIP, HOSE WIRE 11.9mm	16	1	LF4457	RESTRICTOR YELLOW/YELLOW
8	1	5414/90	TUBE 8mm x12mm OD	17	1	LF4458	RESTRICTOR YELLOW/BLUE
9	1	5776A	TAP				



## MIXING, FILLING AND CALIBRATION

Mixing and filling is generally the most hazardous process in the spraying operation. **Always** follow the label instructions. **Always** use a filter (fitted in the backpack tank unit) and use a funnel if filling a container with a small neck. **Only** mix enough spray for the area to be treated thereby avoiding the need for disposal of unused spray mix.

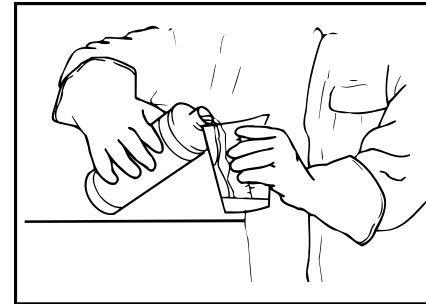

**Always** wear gloves when handling agrochemicals and equipment.

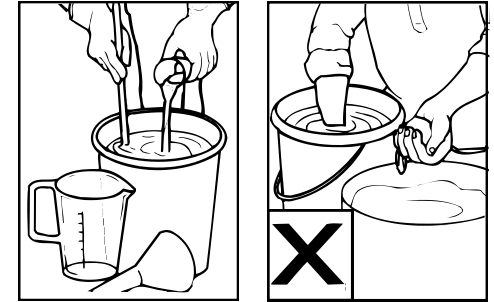

**Always** use the correct equipment when mixing and measuring.

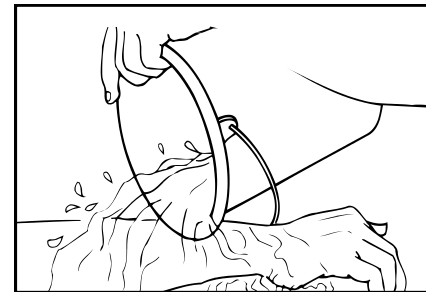

**Always** wash off any skin contamination

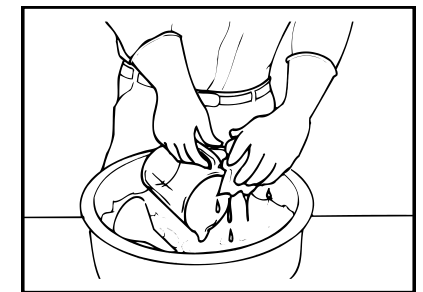

**Always** clean all equipment after use.

With the HANDYDOME herbicides are normally applied at around 50 litres total spray volume per hectare. These are lower volumes than recommended for high volume application with knapsack sprayers. Use the minimum dose rate recommended on the label for the intended treatment and add water to make up to the volume required for application with the HANDYDOME.

**Do not** use herbicide concentrations greater than the maximum recommended on the label (unless specific training or recommendations have been given) if the label:

- a) specifically prohibits use of 'Reduced Volumes' i.e. increased concentrations;
- b) has a statutory requirement for use of personal protective equipment when using the diluted product at high volumes (N.B. this will appear in the statutory box on the label); or
- c) carries one of the following hazard ratings: 'very toxic', 'toxic' or 'corrosive'.

Micron do not generally recommend using spray mixes more than ten times the maximum concentration recommended for high volume application with knapsack sprayers. The safest product and lowest dose rate appropriate for the treatment should be used at all times.

To prepare the spray mix select the dose rate of product to be applied per hectare (from the product label) and mix in a suitable container e.g. the backpack tank unit.

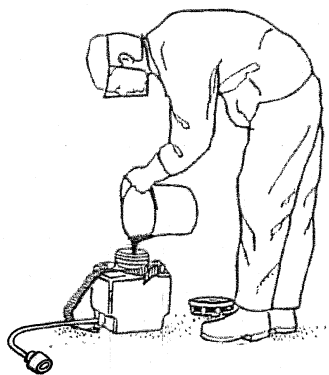

Half fill the backpack tank with clean water and check for leaks.

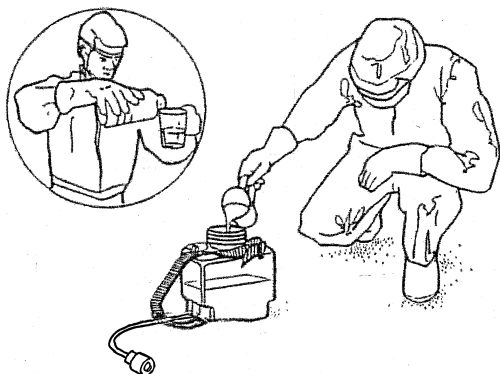

Measure out the exact amount of product and add to the backpack tank.

## POWERPACK PARTS LIST AND DIAGRAM

ITEM No.	QTY.	PART NO.	DESCRIPTION
1	1	7264	BATTERY CASE
2	1	6042	SWITCH SLEEVE
3	1	6043	SWITCH PLUG
4	1	6044	SWITCH CONNECTOR
5	1	5375	CENTRE CONNECTOR
6	1	5363	BATTERY SPRING
7	1	4646	SCREW NO.6 X 3/8 S/T
8	1	5399	SCREW S/T No. 3 X 3/8"
9	3	5575	RING TERMINAL
10	2	5104	SOCKET CONNECTOR
11	1	5095	PLUG, ROUNDED HALF
12	1	5096	PLUG, FLAT HALF
13	2	5109	SCREW, PT,M3 X 6 PAN HD.
14	1	4134/38	WIRE, 1sq mm x 38cm LONG, BLACK
15	2	4368/40	WIRE, 1sq mm x 40cm LONG, RED
16	1	6904	LABEL HANDYDOME
17	1	5466	STRAP RETAINING CLAMP
18	1	4915	SCREW M5 x 16
19	1	4907	WING NUT M5
	1	5107C	STRAP ASSEMBLY

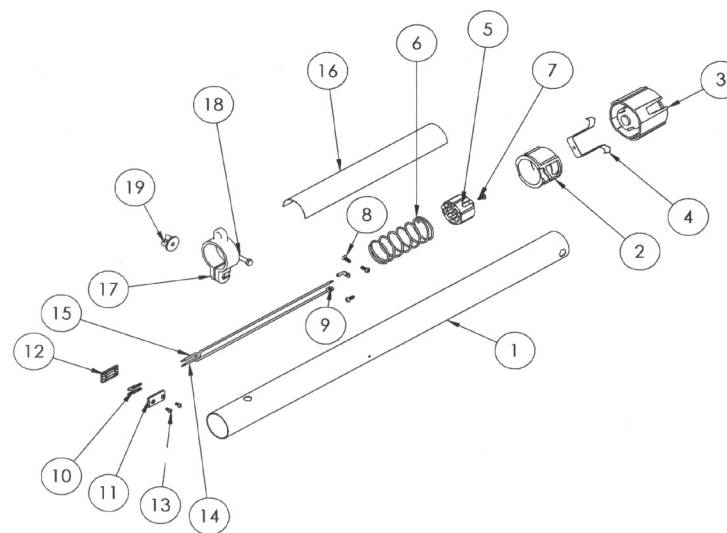

**ATOMISER, PARTS LIST AND DIAGRAM  
MICRON ASSEMBLY PART No. ULP/109**

ITEM No.	QTY	PART NUMBER	DESCRIPTION
1	1	6696	MOTOR HOUSING
2	2	4457	SPRING
3	1	5320	MOTOR
4	1	5398	O RING , BS 012 VITON
5	4	5399	SCREW, S/T, No.6 X 3/8"
6	1	5403	O RING, BS 012, VITON
7	1	5373	ATOMISER DISC
8	1	5372	ATOMISER DISC FIXING SCREW
9	1	5407	WASHER
10	1	5396G	ATOMISER PROTECTIVE COVER
11	1	6695	MOTOR FRONT PLATE
12	2	6717	COVER, TERMINAL
13	1	3512/23	TUBE, NYLON , 1/8" ODX23cm LONG
14	1	4134/24	WIRE, 1 sq mmx24cm LONG, BLACK
15	1	4368/24	WIRE, 1 sq mmx24cm LONG, RED
16	2	5045	EYELET

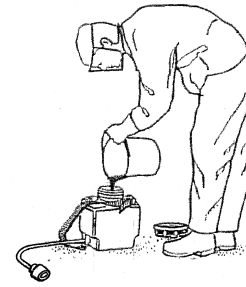
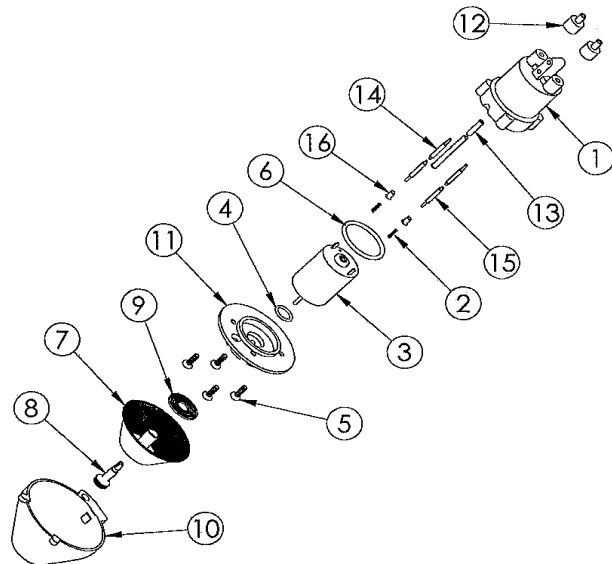

Fill the backpack tank with water and replace the lid .

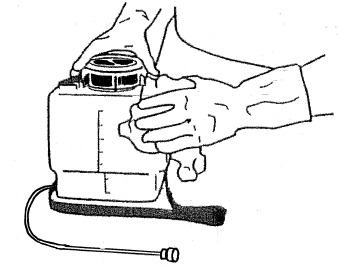

Wipe the backpack tank with a dry cloth.



Mix well by gently shaking the backpack tank.



Place the backpack tank on the operator's back and connect to the HANDYDOME

**Never** use leaking equipment. Take care to avoid spillage of the spray mix.

**BEFORE SPRAYING FOR THE FIRST TIME.**

Check by hand that the atomiser disc spins freely. Before spraying for the first time use water to check the spray pattern produced and familiarise yourself with the sprayer. Put some clean water in the backpack tank unit and add a small amount of detergent (2 to 3 drops). With the sprayer in the correct position (see TO START SPRAYING), check for leaks. Turn the switch end piece clockwise to the ON position to start atomiser motor, now turn on the flow by turning the liquid ON/OFF valve (see Description). Spray on one spot, preferably on clean dry concrete, for about 30 seconds with the spray head held just above and at an angle of five degrees to the ground. A wet ring approx 35 centimetres diameter should appear on the ground. Practice using the sprayer by walking along a few meters. Touch the leading edge of the small fringe fitted to the shroud lightly on the ground and the shroud will be seen to rotate. **It is important to rotate the shroud at all possible times in order for the inbuilt Weedswiper to take effect.**

# Handydome flow restrictors

The details of the 3 restrictors are as below;

**Important note.** The table below is based on water only.

Code	Colours	Size	Flow Rates	L/HA
W-B	Blue & Black	0.66mm	44 mls/min	25.14
Y-Y	Yellow & Yellow	0.99mm	68 mls/min	38.86
Y-B	Yellow & Blue	1.15mm	108 mls/min	61.71

## Important note.

The above table is based on a forward speed of 3 kph and the formula used is;

$$\text{Nozzle flow rate (L/min)} = \frac{\text{Application rate (L/ha treated)} \times \text{Walking speed (kph)} \times \text{Sprayed width (metres)}}{600}$$

You will note from the attached pictures the restrictors simply fit into the outlet side of the in-line liquid feed on/off tap.

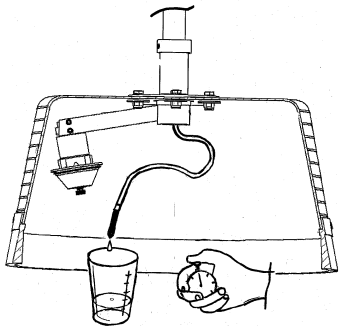
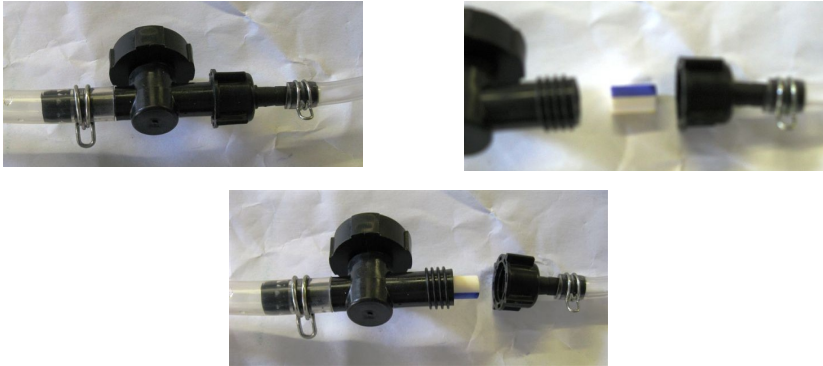

The actual flow rate should be checked holding the HANDYDOME in the spraying position (see 'TO START SPRAYING'). Remove the feed nozzle from the atomiser and allow the liquid to flow into a suitable container .

The yellow feed nozzle is used only to direct the flow into the atomiser disc.

# HANDYDOME SPRAYHEAD AND HANDLE UNIT, DIAGRAM

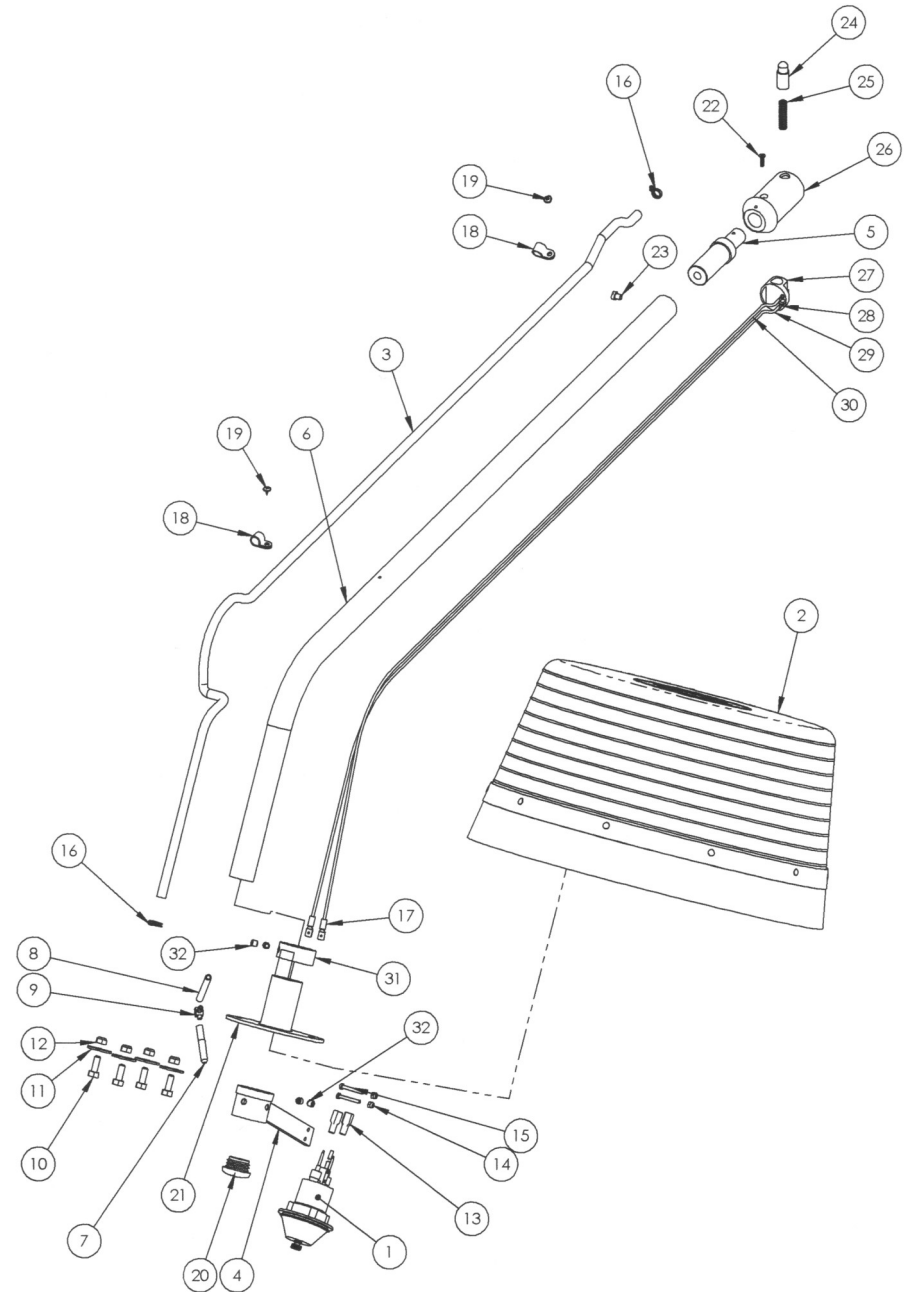

## HANDYDOME SPRAYHEAD AND HANDLE UNIT, PARTS LIST

ITE M	QTY	PART NO	DESCRIPTION
1	1	ULP109	ATOMISER. See Page 14 for parts list
2	1	6854A	BODY, DOME
3	1	4993/2000	TUBE, 6mm OD
4	1	6835	ARM MOUNTING
5	1	7261	SUPPORT ARM
6	1	7260	TUBE MAIN
7	1	7676	NOZZLE YELLOW
8	1	6670_60	TUBE 6 x 4mm
9	1	ZU 023	ELBOW CUT
10	4	5472	SCREW M6 x 16
11	4	5887	WASHER M6
12	4	5984	NUT M6 NYLOC
13	2	6388	RECEPTACLE
14	2	5976	NUT M3 NYLOC
15	2	6884	SCREW M3 x 25
16	2	6028	CLIP HOSE 9.1 WIRE
17	2	6886	RECEPTACLE
18	2	4747	CLIP P
19	2	3472	SCREW NO.6 x 1/4
20	1	7298	INSERT, ROUND
21	1	6650	BUSH FLANGED
22	1	4647	SCREW NO.6 x 3/8
23	1	7073	SCREW M5 x 6
24	1	5086	PUSH BUTTON
25	1	5101	SPRING(PUSH BUTTON)
26	1	6887	CONNECTOR TUBE/BATT CASE
27	1	5085	ELECTRIC SOCKET
28	2	5103	PIN CONNECTOR
29	1	4134_1100	WIRE 1.0sq BLACK
30	1	4368_1100	WIRE 1.0sq RED
31	1	6834	THRUST RING - TOP
32	4	6832	GRUBSCREW M6 x 6

## TO START SPRAYING

Before spraying for the first time check the operation of the sprayer using water and a little detergent only. (see 'BEFORE SPRAYING FOR THE FIRST TIME, page 7)

Switch ON the sprayer by turning the switch end piece clockwise to the ON position. Listen to the motor to check that it is spinning, then turn ON the liquid flow by turning the liquid ON/OFF valve.



Start walking immediately spray liquid is emitted. When spraying, the spray head should be held as close to the ground or the top of the weed canopy as possible with the shroud at an angle of approx. 5 degrees to the horizontal. The leading edge of the fringe fitted to the shroud should be touching the ground or the top of the weed canopy. The shroud will be seen to rotate. **It is important to rotate the shroud as much as possible in order for the inbuilt Weedswiper to take effect.**

At the end of spraying switch OFF the switch end piece.

## AFTER SPRAYING

1. Dispose of any surplus spray mix according to the product approval. Store products safely, locked up and out of the reach of children.



2. It is **essential** to clean the sprayer and backpack tank thoroughly using water and detergent after use. **Never** immerse the spray head in water or under a tap, since this will destroy the electric motor. A water and detergent mix should be put in the backpack tank, swilled around, and disposed of according to local regulations. The sprayer and backpack tank should be wiped down externally using a cloth.
3. Periodically remove and clean the atomiser disc.
4. After working with agrochemicals, or handling spraying equipment, **always** thoroughly wash hands and exposed skin. All protective clothing should be washed separately from other clothing and stored. Contaminated gloves should be washed inside and out.

## TROUBLESHOOTING

### A) Atomiser disc spins but does not spray or sprays irregularly. Check:

- the metering/ calibration nozzle. If the metering/calibration nozzle is blocked remove and soak in soapy water. NB. **Never** blow through the nozzle with your mouth.
- the yellow feed nozzle. If the yellow feed nozzle is blocked remove and soak in soapy water. NB. **Never** blow through the nozzle with your mouth.
- the atomiser disc is clean and undamaged. Clean or replace if necessary.
- the liquid ON/OFF valve for blockage. Clean if necessary.

### B) Atomiser disc fails to spin or spins unevenly. Check

- that the batteries and balance weight are fitted correctly.
- the condition of the batteries. Replace if necessary.
- that electrical terminals and contact points are clean and that electrical wires are not broken or corroded.
- the motor for corrosion or obvious signs of wear. Replace if necessary.
- the atomiser disc is fitted correctly.