

MICRONAIR

AU6539 ELECTRIC ATOMISER & SPEED CONTROLLER

Operator's Handbook and Parts Catalogue

Micron Sprayers Limited
Bromyard Industrial Estate
Bromyard
Herefordshire HR7 4HS
United Kingdom

Tel: (01885) 482397
+44 1885 482397
Fax: (01885) 483043
+44 1885 483043
E-mail: micron@micron.co.uk
Web site: www.micron.co.uk

Iss 6W
10/07

TABLE OF CONTENTS

1.	INTRODUCTION.....	1
2.	SPECIFICATION.....	2
3.	INSTALLATION.....	3
3.1	Mounting of Atomiser.....	3
3.2	Connection of Chemical Feed to Atomiser.....	5
3.2.1	With Variable Restrictor Unit.....	5
3.2.2	With Fixed Restrictor.....	5
3.3	Electrical Connection.....	6
4.	CALIBRATION.....	8
4.1	Droplet Size.....	8
4.2	Flow Rate.....	9
4.2.1	Aircraft Calibration.....	9
4.2.2	Adjustment of Flow Through Atomisers.....	10
5.	HEALTH & SAFETY.....	15
6.	MAINTENANCE.....	16
6.1	Atomiser.....	16
6.2	Motor.....	16
6.2.1	End Cover.....	17
6.2.2	Brushes.....	17
6.3	Variable Restrictor Unit (VRU).....	18
7.	PARTS LISTS.....	20
7.1	AU6539 Atomiser.....	20
7.2	EX6277 Motor.....	22
7.3	EX6307 Variable Restrictor Unit.....	23
7.4	EX6306 Diaphragm Check Valve.....	24
8.	ELECTRONIC SPEED CONTROLLER.....	25
8.1	Specification.....	25
8.1.1	Electronic Unit EX6360.....	25
8.1.2	Control Box EX6358.....	25
8.2	Installation.....	26
8.2.1	Installation of Electronic Unit.....	26
8.2.2	Connection to Aircraft Power Supply.....	26
8.2.3	Connection to Atomisers.....	27
8.2.4	Installation of Controls.....	30
8.3	Operation.....	30
8.4	Maintenance.....	30
9.	CONVERSION FACTORS.....	31

1. INTRODUCTION

The Micronair AU6539 Direct Drive Electric Atomiser is specifically designed for use on helicopters, microlights and specialised installations on fixed wing agricultural aircraft.

The atomiser uses a rotating woven wire gauze cylinder to produce spray droplets within a narrow spectrum of sizes over a wide range of flow rates from a few millilitres/minute to 3 litres/minute. It is intended for the application of a wide range of insecticides, fungicides and other products at low and ultra-low volume rates.

The narrow droplet spectrum ensures that the maximum amount of liquid is sprayed as droplets of the optimum size and minimises wastage or contamination from excessively small or large droplets.

Unlike a conventional pressure nozzle, the atomiser does not have any small holes to block or wear in service.

The atomiser is directly driven by a high speed DC permanent magnet motor. An optional electronic variable speed drive is available to control the atomiser speed.

The spray droplet size is determined by the atomiser rotational speed. If installed, the speed controller can be adjusted to give the correct rotational speed for the optimum droplet size for a wide range of applications.

The high efficiency electric motor ensures minimum power consumption and enables the atomiser to be used on aircraft with electrical systems of limited capacity.

The compact, lightweight design of the atomiser enables it to be mounted directly onto many standard spray booms without structural modification. A range of boom clamps is available to suit all standard round and streamline boom sections.

Each atomiser is supplied with a full installation kit which includes the boom clamp, either a Micronair Variable Restrictor Unit (VRU) or a set of fixed restrictors for quick and easy selection of chemical flow rate, a diaphragm check valve to prevent dripping of chemical when not spraying and all necessary hoses, fittings etc.

If the speed controller is required, it must be ordered separately. Each unit can control the speed of up to six atomisers. The speed control is supplied with a complete installation kit, which includes the electronic unit, speed control potentiometer, control switch, connectors etc. Full instructions for the installation of the speed control are included in a separate section of this handbook.

2. SPECIFICATION – ATOMISER

Model Number:	AU6539
Dimensions:	8" (203 mm) L x 3.4" (85 mm) Dia [1]
Weight:	4.4 lb (2 Kg)
Input Voltage:	24 – 28 V DC [2]
Input Current:	6 A [3]
Liquid Flow Rate:	0.05 – 3 l/min
Rotational Speed:	2,000 – 11,000 RPM [4]
Droplet Size:	45 – 120 microns VMD (See graph 1) [5]
Boom Clamps:	Available to fit the following boom sizes:

Boom size	Part No
1" (25 mm) round	EX6281
1 1/8" (28.5 mm) round	EX6282
1 1/4" (32 mm) round	EX6283
1 3/8" (35 mm) round	EX6284
1 1/2" (38 mm) round	EX6285
1.57" (40 mm) round	EX6981
1 5/8" (41 mm) round	EX6286
1 3/4" (44 mm) round	EX6748
1 7/8" (48 mm) round	EX6993
2" (51 mm) round	EX6922
2.2" x 1.1" (56 x 28 mm) streamline	EX6287
2.75" x 1" (70 x 25 mm) streamline	EX6289
2" diameter with flats 1" deep [6]	EX6969

Notes:

1. Excluding pipe fittings, boom clamp, cable etc.
2. When connected directly to aircraft electrical system. Voltage can be varied by optional speed controller when fitted.
3. At 24V input and 3 l/min flow rate.
4. Atomiser speed is only variable when the optional speed controller is fitted. Atomisers will run at maximum speed without the controller.
5. Droplet size is influenced by the physical properties of the liquid being sprayed. Droplet size is determined by atomiser rotational speed and can only be varied when optional speed controller is fitted.
6. As used on some Isolair booms.

3. INSTALLATION

3.1 Mounting of Atomiser

AU6539 atomisers are supplied with a range of cast aluminium alloy mounting clamps to suit all popular spray boom sections (see Specification section for details of sizes and part numbers).

The mounting clamps can be used to install the atomisers on many standard spray booms without structural modification. However, the strength and stability of different types of spray booms vary considerably and the strength of a boom can be reduced by corrosion, damage and other factors.

IMPORTANT: It is the responsibility of the installer of the equipment to ensure that the boom is of adequate strength and stability and is in satisfactory condition to carry the required number of atomisers. It is also the responsibility of the installer to ensure that all applicable airworthiness requirements are met and that all necessary technical data is provided for the approval of the installation.

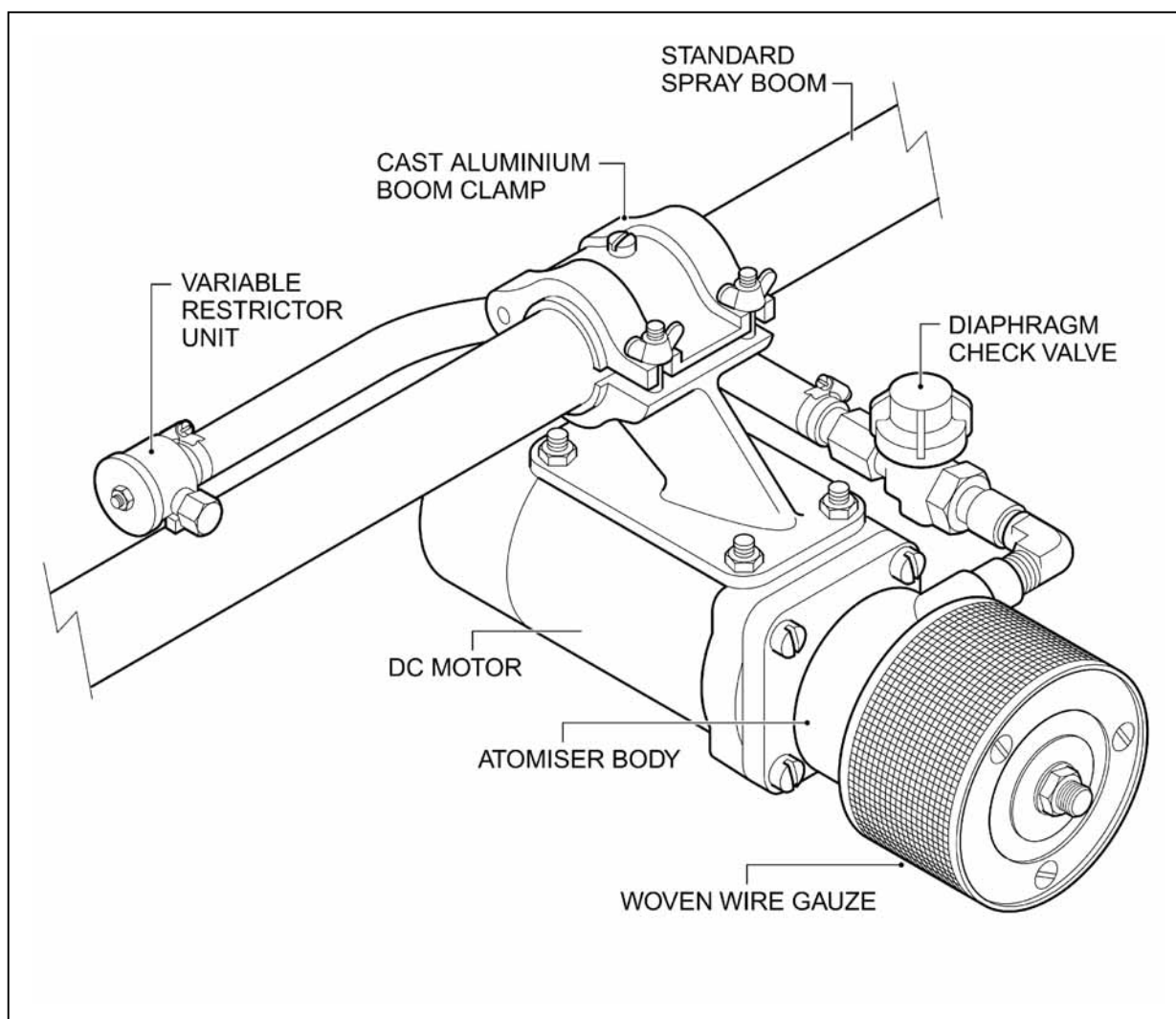

Fig. 1 – Typical Installation of Direct Drive Electric Atomiser

These instructions describe a typical installation as shown in Fig. 1 and are provided as an example only. Details of the installation may vary with boom configuration.

1. If round section spray booms are being used, rotate the booms until the nozzle holes are at the top of the boom and are vertical with the aircraft in the flight attitude. Clamp the booms securely and ensure that they cannot rotate in their mountings.
2. Measure the booms and mark the positions of the atomisers. Although the final positions are best determined by assessment of the swath deposition on the ground and by observation in flight, the following procedure should provide an acceptable starting point:
 - i. Position the outboard atomisers at 67% of the wing span of a fixed wing aircraft or rotor disc diameter of a helicopter.
 - ii. Position the inboard atomisers between 12 - 36 inches (300 - 900 mm) outboard of the fuselage. The position must be chosen to be clear of any structure and minimise the risk of contamination of the fuselage or tail rotor by spray from the atomisers.
 - iii. Space the remaining atomisers equally between the inboard and outboard units. Note that it may be necessary to adjust the positions slightly to clear boom support brackets etc.

If round spray booms are being used, the final positions for the atomisers should be adjusted to correspond with the nearest nozzle holes.

It is vital that there is adequate ground clearance below the atomisers when installed on the booms. With some helicopter boom installations it is possible to adjust the geometry of the boom structure to vary the ground clearance.

3. If round spray booms are being used, screw a retaining peg (EX1517) in the nozzle hole corresponding to each atomiser position. Use the PTFE tape provided to seal the threads.
4. Remove the wing nuts from the clamp and, if required, fit the split bushes inside the clamp to provide the correct inside diameter for the boom.
5. Fit the clamp over the boom, ensuring that the end of the plate below the clamp with two mounting holes faces aft and (if applicable) the locating peg on the boom passes through the hole in the clamp.
6. Tighten the wing nuts firmly by hand. Do not over-tighten the nuts with pliers or a wrench.
7. Wire (safety) lock the wing nuts together, using the holes provided.
8. Remove the self-locking nuts and washers from the studs on the atomiser motor body and mount the atomiser below the clamp with the studs passing through the holes in the plate. Re-fit the nuts and washers and tighten the nuts.

3.2 Connection of Chemical Feed to Atomiser

AU6539 atomisers can be used with either Variable Restrictor Units (VRUs) or fixed restrictor orifice plates to regulate the flow of spray liquid to each unit. The installation procedures for these are as follows:

3.2.1 With Variable Restrictor Unit

1. Remove the cap nut and adaptor from the outlet of the diaphragm check valve EX6306 (Fig. 6, Items 5 and 6).
2. With the cap nut still in position on the stem of the outlet adaptor (6), screw the adaptor into the feed elbow of the atomiser. Seal the thread with the PTFE tape provided.
3. Screw the cap nut back onto the diaphragm check valve body, ensuring that the filter (4) is in position inside the valve body and that the valve cap faces upwards to minimise chemical spillage when it is opened.
4. Locate a suitable nozzle hole adjacent to each atomiser for the mounting of the VRU (see Fig. 1). The positions should be chosen so that the hoses between the VRUs and the atomisers will not kink or chafe on the clamps. The VRUs feeding the outboard atomisers should be fitted as close as possible to the ends of the booms to prevent air pockets forming in the outboard ends of the booms.
5. Each VRU has two threaded inlet fittings. Close the inlet which will not be screwed into the nozzle hole on the boom with a blanking cap (EX1670 for the 1/8" NPT inlet or EX1671 for the 1/4" NPT inlet). Seal the thread with PTFE tape.
6. Screw the inlet fitting of each VRU into the nozzle hole identified in step (4) above, ensuring that the outlet hose fitting faces towards the atomiser. Seal the thread with PTFE tape. Some streamline section spray booms have nozzle holes recessed into the trailing edge. This may cause the VRU body to touch the boom before the thread tightens. Should this be the case, it will be necessary to fit stand-off adaptors EX2313 between the boom and VRU inlets.
7. Connect each VRU outlet to the corresponding check valve inlet with the ½" flexible hose (CBP991) and hose clips (CBP11) provided. See Fig. 1 for details. If necessary, secure the hose to the boom or clamp with plastic cable ties to prevent it from moving or chaffing. Do not over-tighten the cable ties to prevent crushing the hose.

3.2.2 With Fixed Restrictor

1. Remove the cap nut and adaptor from the outlet of the diaphragm check valve CBP2537 (Fig. 6, Items 5 and 6).
2. With the cap nut still in position on the stem of the outlet adaptor (6), screw the adaptor into the feed elbow of the atomiser. Seal the thread with the PTFE tape provided.
3. Select the restrictor orifice plate to be used (see Calibration section) and place it inside the cap nut so that the raised face lies against the metal outlet adaptor (see Fig. 6).

4. Screw the cap nut back onto the diaphragm check valve body, ensuring that the filter (4) is in position inside the valve body and that the valve cap faces upwards to minimise chemical spillage when it is opened.
5. Connect a feed hose from an adjacent nozzle hole to the inlet fitting of the diaphragm check valve. The hoses feeding the outboard atomisers should be fitted to nozzle holes as close as possible to the ends of the booms to prevent air pockets forming in the outboard ends of the booms.
6. If necessary, secure any loose lengths of hose to the booms or clamps with plastic cable ties to prevent them from moving or chaffing. Do not over-tighten the cable ties to prevent crushing the hose.

3.3 Electrical Connection

The atomisers can be connected either directly to the 24 – 28 V DC aircraft supply or to an electronic speed controller. These instructions apply to installations without a speed control. If a speed control is being fitted, disregard this section and refer to the Speed Controller section at the end of this Handbook.

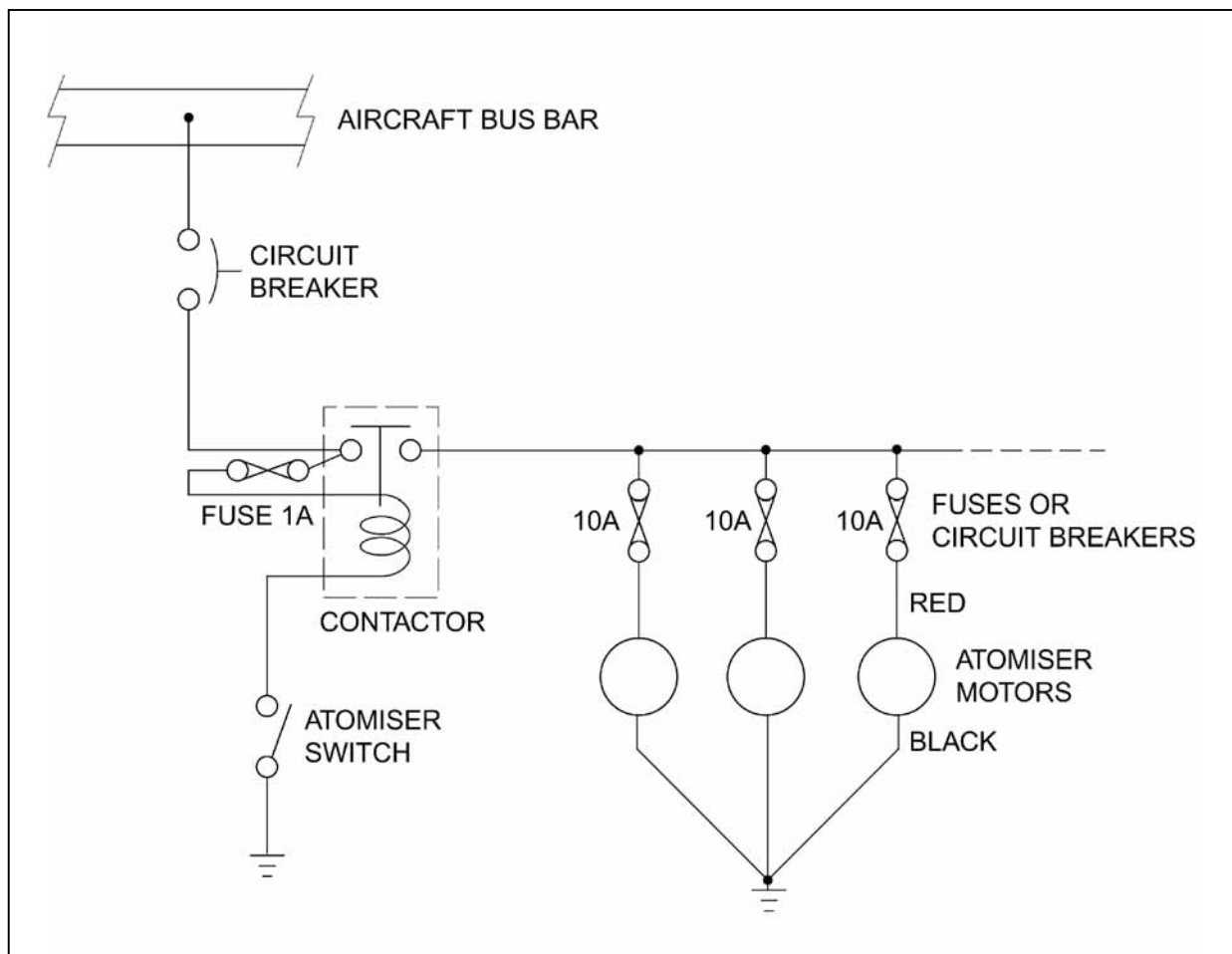

Fig. 2 – Electrical Connection

IMPORTANT: It is the responsibility of the installer to ensure that the aircraft electrical system has sufficient spare capacity to operate the atomisers. It is also the installer's responsibility to provide the necessary wiring and components to connect the atomisers to the aircraft electrical system and to ensure that the installation and circuit protection meet all applicable airworthiness standards.

The following steps describe a typical installation as shown in the schematic diagram in Fig. 2:

1. Select a suitable type of approved wire for the connection of the atomisers. The insulation should be robust and chemical resistant. The gauge of the conductors should be adequate for the current consumption of the motors (see Specification and Graph 4), the rating of the fuse or circuit breaker (see 5 below) and to prevent an excessive voltage drop (and hence reduction in atomiser speed) under load. The minimum recommended conductor size is 12 AWG for each motor.
2. Using the push-on connectors provided, connect the negative (black) lead from each atomiser motor to a wire connected to airframe ground. Note that the spray boom is not a satisfactory ground and all wires should be taken to a grounding point on the main structure.
3. Connect a separate wire to each positive (red) motor lead and route all wires along the booms to the fuselage.
4. Protect all wiring with chemical and abrasion resistant sleeving and secure firmly to the boom and aircraft structure with plastic cable ties.
5. Connect each atomiser positive wire to an individual fuse or circuit breaker. These should be rated at 10 A each.
6. Connect the supply to all fuses or circuit breakers installed in (5) above to a suitably rated relay or contactor. The minimum contact rating is 10 A (inductive) per atomiser (ie 60 A for a 6 unit installation).
7. Connect the supply to the relay or contactor to the aircraft bus bar or battery positive terminal by means of a fuse or circuit breaker of a rating appropriate to protect the contactor and wiring.
8. Connect a 1 A fuse between one terminal of the relay or contactor coil and the positive supply from the battery.
9. Install a switch to control the atomisers in a convenient position in the cockpit.
10. Connect one side of the switch to the relay or contactor coil and the other to airframe ground. The minimum wire gauge for these connections should be 20 AWG if a 1 A fuse is fitted at step (8).
11. Secure all wiring with plastic cable ties to prevent vibration or chaffing.
12. Test the system by connecting the battery and operating the control switch. All atomisers should start and stop simultaneously and all should run at the same speed.

If possible, the speeds of all atomisers should be checked with a hand tachometer. The speeds should be within approximately 5% of the average. Should one or more atomisers run more slowly, it is likely that there is an excessive voltage drop across its wiring, the ground connection or its fuse or circuit breaker. This can be checked with a voltmeter and by comparing the atomiser speed shown in Graph 2 with the voltage across the motor leads (measured at the push-on connectors adjacent to the motor).

IMPORTANT: All atomisers should rotate clockwise when viewed on the end of the gauze. If an atomiser rotates anti-clockwise, this indicates that its red and black leads have been reversed. This must be corrected before use.

4. CALIBRATION

4.1 Droplet Size

The size of the spray droplets produced by an AU6539 atomiser depends upon the rotational speed of the gauze and the properties of the liquid being sprayed.

Graph 1 shows the measured relationship between droplet Volume Median Diameter (VMD) and rotational speed for water, a typical ULV formulation and a biological (Bt) insecticide.

If a speed controller is fitted, atomiser speed can be varied from 500 RPM to the maximum possible at the aircraft supply voltage. If a speed controller is not fitted, the atomisers will all run at maximum speed.

The maximum atomiser speed will depend upon the aircraft supply voltage and any voltage drops along the wiring (see Installation section). The normal range is shown on Graph 2.

The supply voltage will normally be higher when the aircraft engine is running and charging the battery. Care should be taken if calibrating the system with a ground power unit as its output voltage may not be the same as the aircraft battery voltage whilst it is being charged with the engine running.

The speed of an atomiser should be checked with a hand-held tachometer. This can either be a mechanical type driven from the nut at the end of the motor shaft behind the atomiser gauze or an optical type. If an optical tachometer is used, a black card disc with a reflective mark should be trapped under the nut at the end of the motor shaft.

The speed of an atomiser will reduce slightly due to the load of the liquid being sprayed. The relationship between the percentage speed drop and flow rate is shown in Graph 3. As it is only practical to measure the atomiser speed when not spraying, the speed of the atomisers should be set higher than required under load by the amount shown in Graph 3 (eg set speed to 1.05 times the required speed to allow for a 5% drop under load).

The procedure to set the atomisers to the correct speed with a speed controller is as follows:

-
1. Refer to Graph 1 and determine the correct rotational speed for the droplet size required and the type of liquid being sprayed.
 2. Determine the flow rate of liquid through each atomiser (see Flow Rate Calibration section below).
 3. Refer to Graph 3 and determine the percentage reduction in speed due to the load of the liquid.
 4. Calculate the corrected dry rotational speed by INCREASING the speed found in step (1) by the percentage found in step (3).
 5. Using a hand-held tachometer as described above, adjust the speed control until the average rotational speed of all atomisers is as calculated in step (4). Check the speed of all atomisers and ensure that no units are running excessively slow or fast.

4.2 Flow Rate

The flow of liquid through each atomiser is determined by the boom pressure and the setting of the Variable Restrictor Unit (VRU) or the size of the fixed orifice plate fitted in the diaphragm check valve outlet.

The droplet size produced by the atomiser is independent of boom pressure, so the pressure can be varied to provide the correct application rate without affecting the droplet size.

4.2.1 Aircraft Calibration

In order to establish the correct adjustment of each atomiser, it is first necessary to determine the total output from the aircraft. The procedure is as follows:

1. Refer to Table 1 or 2 or use the formula to determine the coverage of the aircraft in hectares or acres per minute at the operating airspeed and swath width (track spacing).
2. Multiply this figure by the required application rate in litres/hectare or gallons/acre to give the output from the aircraft in litres or gallons per minute.
3. Divide this by the number of atomisers to determine the output from each atomiser.
4. **If using VRUs:** refer to Graph 5 to establish the appropriate setting for the restrictors. Note that the standard VRUs supplied with AU6539 atomisers are fitted with low (/L) numbered restrictor plates with hole sizes 1 – 7. Adjust all VRUs to the correct setting number by rotating the red cap until the appropriate number on the cap aligns with the line on the body. There are two sets of numbers on the knob. Even numbers are marked on the end of the cap and odd numbers are on the side. Only numbers 1 – 7 are used, so numbers 8 – 13 should be ignored.

If using fixed restrictor orifice plates: refer to Graph 6 and select the appropriate plate for the required flow rate. Fit the appropriate restrictor plates in the outlet of the diaphragm check valve as described in the Installation section.

The VRU setting or restrictor plate size should be chosen to give the required flow rate at a boom pressure of between 20 – 40 PSI (1.5 – 3 Bar). The use of a lower pressure may not give a consistent output from all atomisers and higher pressures can result in unnecessary wear and tear on the system.

Note that the figures in this Handbook are based on tests with water. Actual flow rates will depend upon the properties (especially viscosity) of the liquid being sprayed. Actual flow rates must always be checked.

4.2.2 Adjustment of Flow Rate Through Atomisers on Ground

If the aircraft has a power driven chemical pump it will be possible to adjust and check the flow rate from each atomiser on the ground. The procedure is as follows:

1. Fill the aircraft chemical tank with the product to be used (or a liquid of similar viscosity).
2. Set all VRUs to the position determined above or fit the appropriate fixed restrictor orifice plates.
3. Run the spray liquid pump to purge all air from the system and set the boom pressure.
4. Place a suitable container (eg a plastic bag or bucket) under each atomiser. Do not run the atomisers.
5. Open the boom valve for 1 minute or part of a minute depending on the rate of flow and size of container.
6. Measure the contents of each container and calculate the rate of flow from each atomiser. If this is insufficient, increase the boom pressure or select the next larger VRU orifice (higher number) or restrictor plate. If the output is excessive, reduce the boom pressure or select a smaller orifice.
7. Repeat steps (4 – 6) until the correct settings are found.
8. Having established the appropriate VRU orifice and approximate boom pressure, the final adjustment of boom pressure must be made in flight.

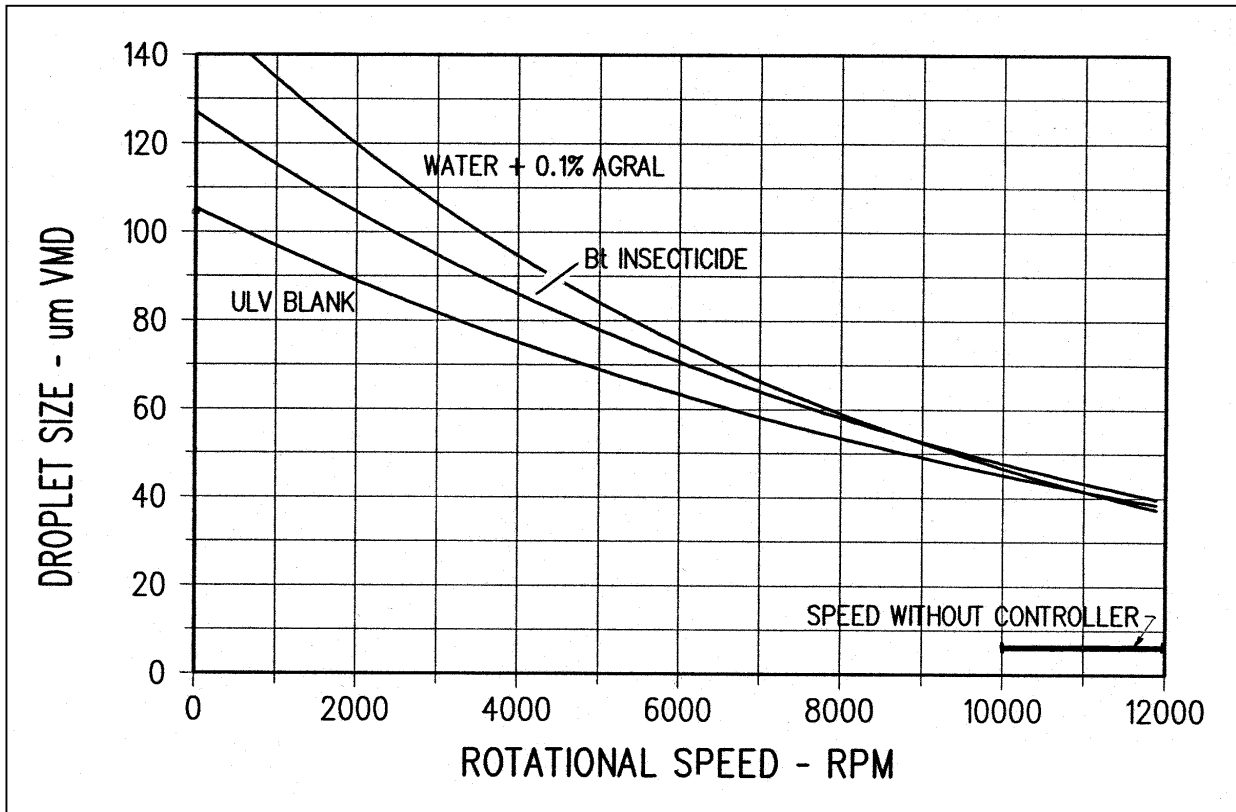

Graph 1 – Relationship Between Rotational Speed & Droplet Diameter for Typical Spray Liquids

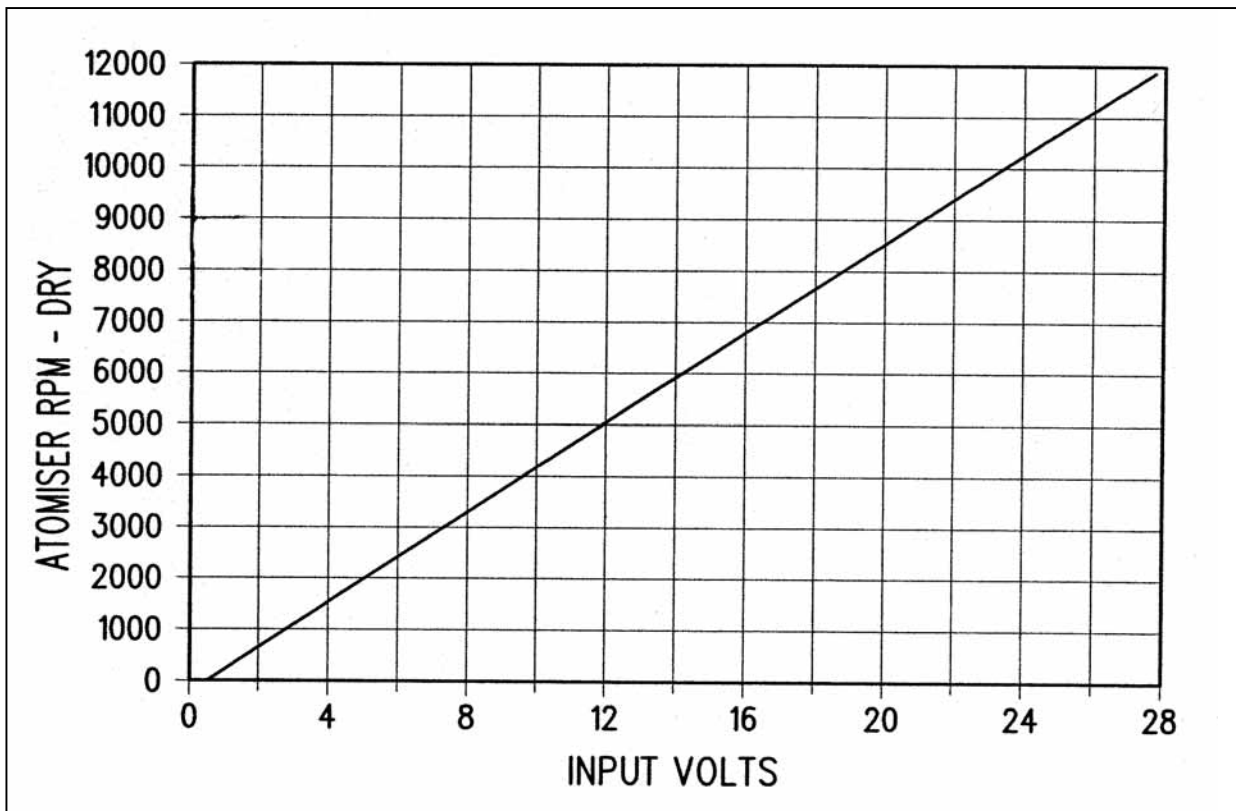

Graph 2 – Relationship Between Rotational Speed & Supply Voltage to Atomiser Motor

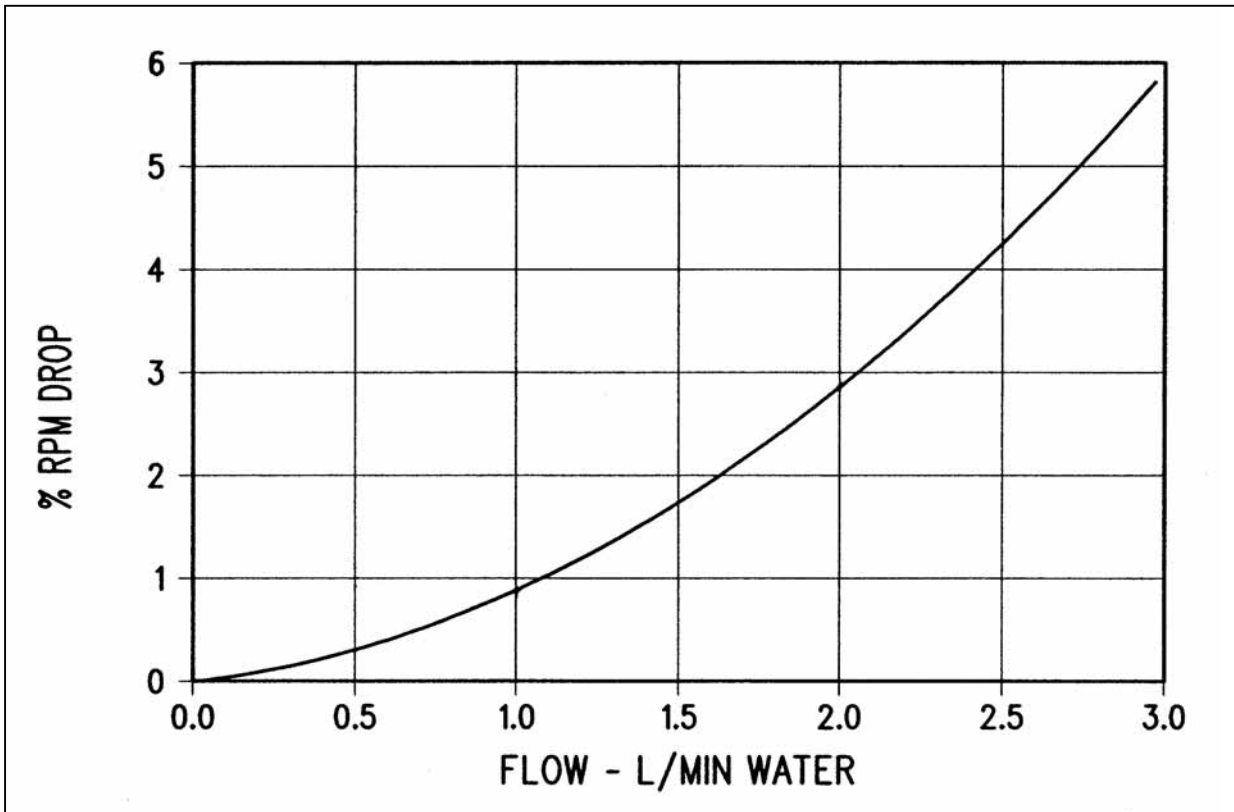

Graph 3 – Effect of Liquid Flow Rate on Rotational Speed of Atomiser

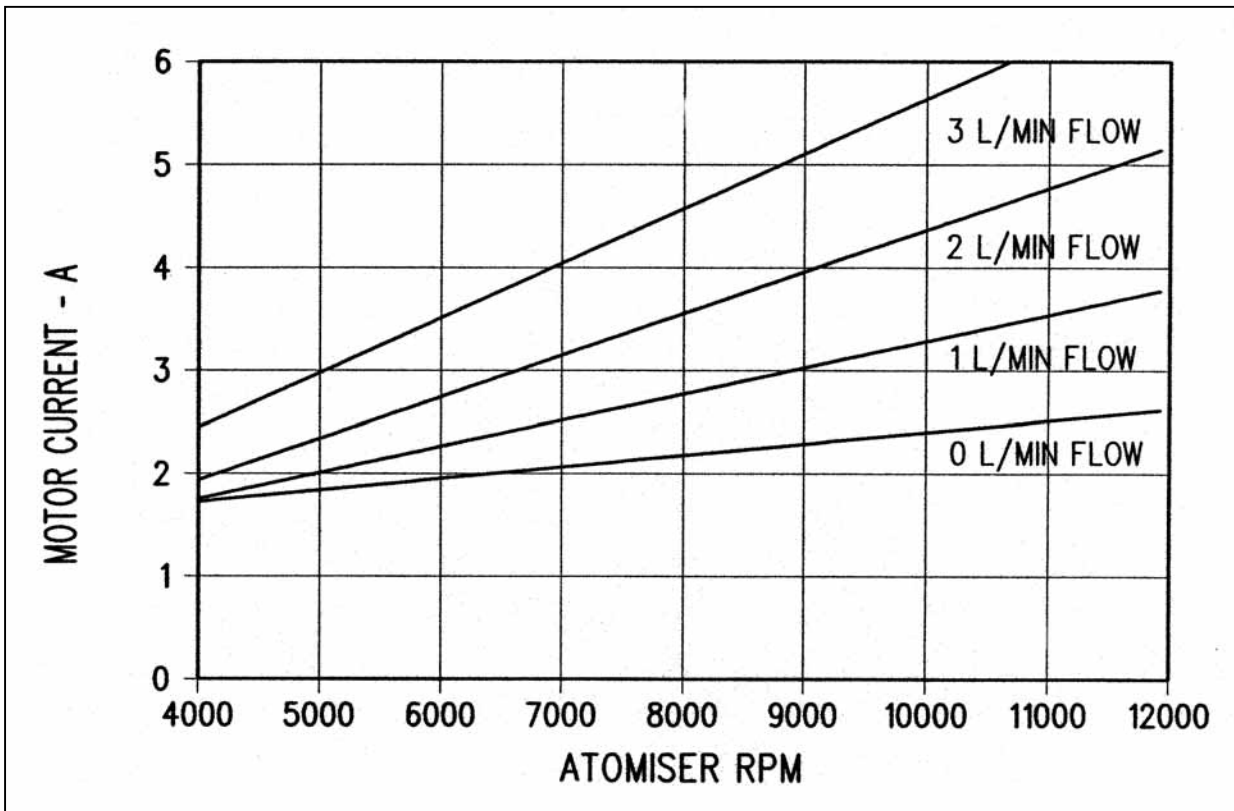

Graph 4 – Input Current to Motor

SWATH WIDTH – METRES										
SPEED Km/hr	12	14	16	18	20	30	40	50	75	100
85	1.7	1.9	2.2	2.5	2.8	4.2	5.6	7.0	10.6	14.1
90	1.8	2.1	2.4	2.7	3.0	4.5	6.0	7.5	11.3	15.0
95	1.9	2.2	2.5	2.8	3.1	4.8	6.3	7.9	11.8	15.8
100	2.0	2.3	2.6	3.0	3.3	5.0	6.6	8.3	12.5	16.6
110	2.2	2.5	2.9	3.3	3.6	5.5	7.3	9.1	13.8	18.3
120	2.4	2.8	3.2	3.6	4.0	6.0	8.0	10.0	15.0	20.0
130	2.6	3.0	3.4	3.9	4.3	6.5	8.6	10.8	16.3	21.6
140	2.8	3.2	3.7	4.2	4.6	7.0	9.3	11.6	17.5	23.3
150	3.0	3.5	4.0	4.5	5.0	7.5	9.3	12.5	18.8	25.0
160	3.2	3.7	4.2	4.8	5.3	8.0	10.6	13.3	20.0	26.6
170	3.4	3.9	4.5	5.1	5.6	8.5	11.3	14.1	21.3	28.3

FORMULA: Hectares/min = $\frac{\text{Speed (Km/hr)} \times \text{Swath (m)}}{600}$

Table 1 – Hectares Sprayed per Minute

SWATH WIDTH – FEET										
SPEED MPH	30	35	40	45	50	75	100	200	300	500
75	4.5	5.2	6.0	6.7	7.5	11.2	15.0	30.0	45.0	75.0
80	4.8	5.6	6.4	7.2	8.0	12.0	16.0	32.0	48.0	80.0
85	5.1	5.9	6.8	7.6	8.5	12.7	17.0	34.0	51.0	85.0
90	5.4	6.3	7.2	8.1	9.0	13.5	18.0	36.0	54.0	90.0
95	5.7	6.6	7.6	8.5	9.5	14.2	19.0	38.0	57.0	95.0
100	6.0	7.0	8.0	9.0	10.0	15.0	20.0	40.0	60.0	100.0
110	6.6	7.7	8.8	9.9	11.0	16.5	22.0	44.0	66.0	110.0
120	7.2	8.4	9.6	10.8	12.0	18.0	24.0	48.0	72.0	120.0
130	7.8	9.1	10.4	11.7	13.0	19.5	26.0	52.0	78.0	130.0
140	8.4	9.8	11.2	12.6	14.0	21.0	28.0	56.0	84.0	140.0
150	9.0	10.5	12.0	13.5	15.0	22.5	30.0	60.0	90.0	150.0

FORMULA: Acres/min (approx) = $\frac{\text{Speed (MPH)} \times \text{Swath (feet)}}{500}$

Table 2 – Acres Sprayed per Minute

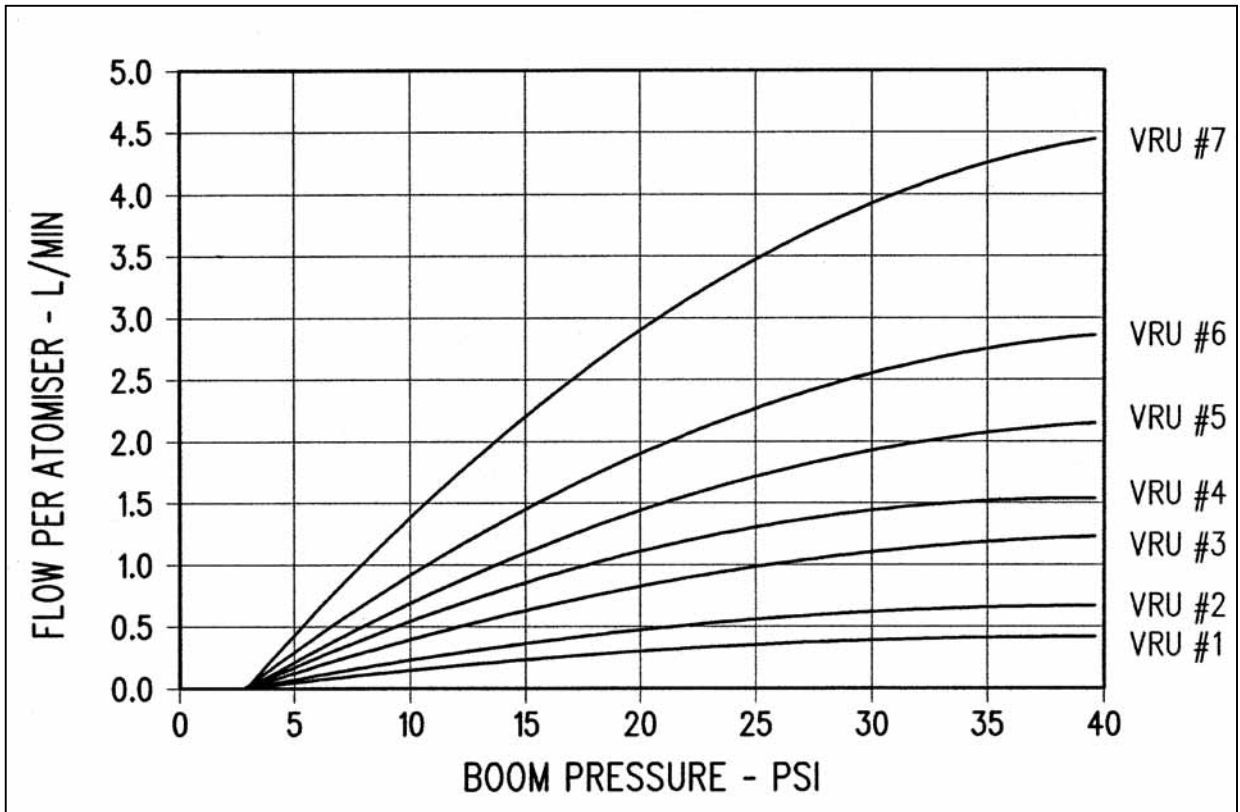

Graph 5 – Liquid Flow Rate Through Variable Restrictor Unit Fitted with Low (L) Numbered Plate

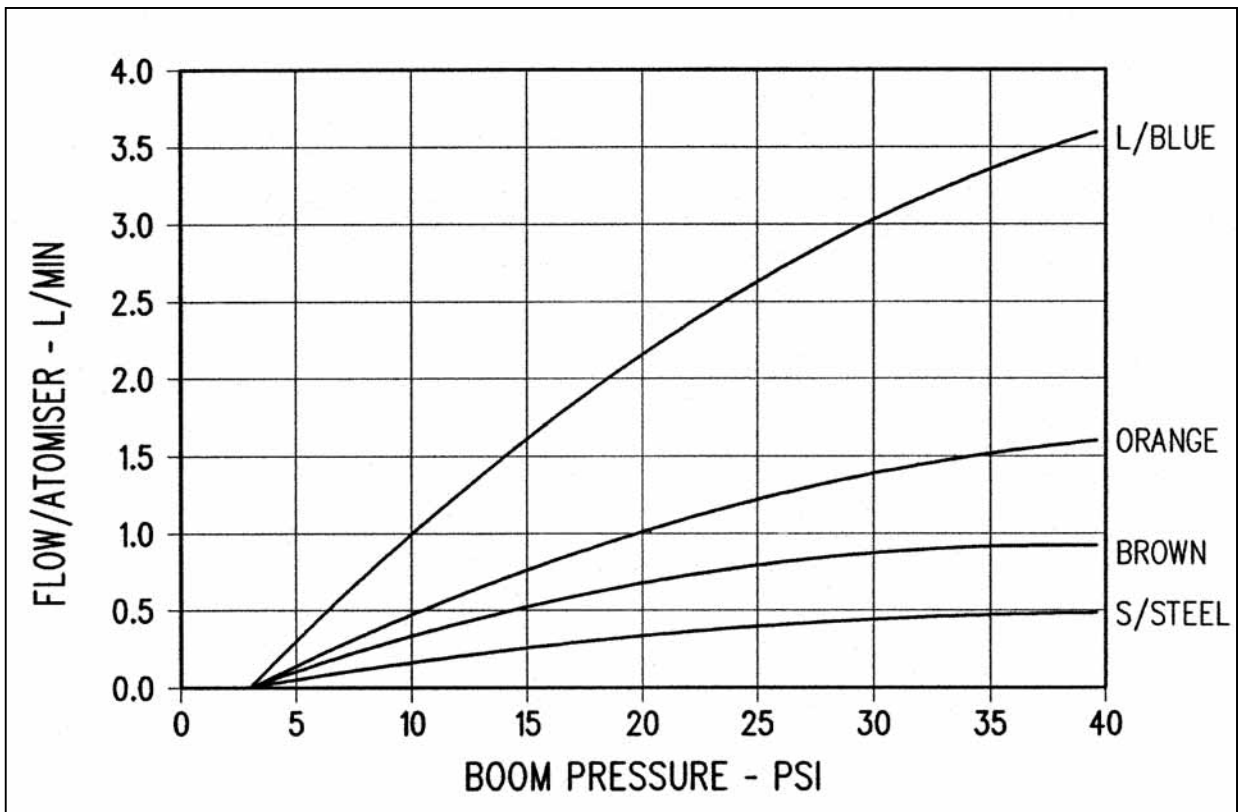

Graph 6 – Liquid Flow Through Fixed Restrictor Orifice plates

5. HEALTH AND SAFETY

Legislation regarding the application of chemicals that are potentially harmful to individuals or the environment varies considerably between countries. Operators using chemicals and equipment must ensure they are working within the regulations applicable to their area.

Irrespective of legislation, Micron Sprayers advise the users of their equipment that all possible care must be taken to ensure the health and safety of the user and personnel in the vicinity of the spraying operation.

The following recommendations are for guidance only and do not exclude any statutory requirement:

1. The application of each chemical should follow the recommendations of the manufacturer. Extreme care should be taken to prevent chemical reaching the operator or any other people, animals or neighbouring crops where contamination could have an adverse effect.
2. Ensure that the equipment is correctly calibrated for the chemical being used.
3. Suitable clothing, eye protection and masks must be worn when working with or near toxic chemicals and operators must adhere to all relevant handling precautions and regulations.
4. The entire spray system and all ancillary equipment must be thoroughly washed out after use or before maintenance.
5. All chemical residues must be safely stored or disposed of.
6. All used chemical containers must be safely disposed of in accordance with local regulations and requirements.
7. First aid and washing facilities must always be available and personnel must be trained in their use.

6. MAINTENANCE

6.1 Atomiser

The AU6539 atomiser is designed for easy maintenance and cleaning. The procedure to dismantle the atomiser is as follows (the parts are identified by their numbers in Fig. 3):

1. Remove the M8 nut (15) from the end of the motor shaft and pull off the gauze (4) and hub body (3).
2. If necessary, the gauze can be removed from the hub body for replacement or cleaning by removing the three countersunk screws (14).
3. If necessary, the inner gauze (5) can be removed from the inside of the hub body for cleaning by reaching inside the bore of the hub with a pair of long-nose pliers, gripping the free end of the gauze and winding it inwards.
4. Unscrew the feed ring (2) from the end of the feed body. If the ring is more than finger tight, it may be unscrewed by wrapping a piece of cloth or rubber round it and gripping it gently with a pair of large pliers. Do not grip the ring directly with metal jaws.
5. If necessary, the 'O' rings (8 & 9) may be removed from the outside of the feed body by prying them out with a small screwdriver. Take care not to damage the edges of the 'O' ring grooves.
6. If necessary, remove the feed body from the motor by removing the four M5 pan head screws (12).

After dismantling the atomiser, clean all parts with a suitable solvent for the chemical that has been sprayed, followed by clean water and detergent.

Check all parts, especially the seals, for damage or wear and replace as necessary.

Apply a light film of grease to the 'O' ring and 'V' ring seals and re-assemble the atomiser by reversing the dismantling procedure. Do not over-tighten the feed ring on the feed body. This should be screwed on finger-tight until the gap between the edge of the feed ring and the step on the body is completely closed.

6.2 Motor

Should the motor require maintenance, it is preferable to fit a service exchange unit.

If the necessary facilities and spares are available, motors can be repaired in the field. The procedure is as follows:

6.2.1 End Cover

1. Remove the two screws securing the black plastic end cover.
2. Run a thin knife blade around the join between the end cover and metal motor housing to break the seal between the two.
3. Pull off the end cover. If the seal cannot be broken with a knife, it may be necessary to destroy the cover to remove it. In this case, a spare must be available to re-fit.
4. When the cover is replaced, the joint between the cover and the motor housing must be sealed with a bead of non-corrosive silicone rubber sealant (Dow Corning RTV738 or similar) applied before pushing on the cover. The underside of the screw heads should also be sealed with a small bead of sealant.

6.2.2 Brushes

Both carbon brushes must always be replaced at the same time. The procedure is as follows:

1. Remove the screws and washers holding the motor and brush leads to the insulator.

IMPORTANT: Do not drop the screws or washers into the motor. They will be attracted to the magnets in the body and can be very difficult to retrieve.
--

2. Lift the ends of the brush retaining springs and carefully move them sideways onto the insulator to clear the brushes.
3. Remove the old brushes and clean the inside of the brush guide slots in the insulator with compressed air.
4. Replace both brushes, ensuring that their leads face towards the flange of the insulator.
5. Lift the ends of the brush retaining springs and place them onto the ends of the brushes. Ensure that the springs align with the slots in the insulator and exert pressure on the brushes.
6. Replace the screws and washers. Ensure that the brush leads are placed immediately under the screw heads, then the motor leads and finally the star washers against the insulator.
7. Test the motor by running it on a 24 V DC supply before replacing the end cover.

6.3 Variable Restrictor Unit (VRU)

Each VRU should be checked and cleaned periodically. Should it be necessary to dismantle the unit, the procedure is as follows:

1. Remove the VRU by disconnecting the outlet hose and unscrewing the unit from the boom.
2. Remove the red knob by unscrewing the 10-32 nut in the centre. Ensure that the washers on either side of the knob cap are not lost.
3. Using a spanner, unscrew the outlet fitting of the VRU. If this is tight, the body must be held by two locating holes under the thimble at the opposite end to the outlet. A special key, Micronair part number EX1942, is available to assist in dismantling the VRU.

IMPORTANT: Do not clamp the VRU by its body or inlet pipes as these may be permanently damaged.

4. Remove the orifice plate from the body and slide out the selector plate assembly and spring.
5. The shaft is sealed by a gland that is retained by a brass ring at the end of the body. This should not be disturbed unless the gland requires replacing. If replacement is necessary, the brass ring should be unscrewed and the old packing eased out of its seat.

Before re-assembly, all parts must be thoroughly cleaned. Particular attention must be given to the faces of the orifice and selector plates, the selector shaft and the indexing grooves inside the knob.

The assembly procedure is as follows:

1. If the gland packing has been removed: fit a new packing into the seat in the body and screw down the retaining ring so that it just touches the packing. **DO NOT TIGHTEN AT THIS STAGE.**
2. Fit the spring against the selector plate and insert the assembly into the body, passing the shaft through the gland packing.

IMPORTANT: Do not allow the step at the end of the shaft to damage the gland in the body.

3. Position the orifice plate in the body, making certain that the FLAT face rests against the selector plate and the locating pin engages in the hole inside the body.
4. Screw the outlet into the body and tighten with a spanner.

5. If the gland packing has been replaced or if the gland has shown signs of leaking: tighten the gland retaining ring to compress the packing. The ring should be tightened about half a turn before rotating the shaft. This procedure should be repeated until the shaft has seated into the packing. Loosen the ring slightly to enable the plates to close positively. If the shaft has a tendency to stick, check that the spring has sufficient tension to overcome any resistance in the gland packing. If the packing shows signs of being tight or dry, lubricate the packing with light grease.
6. Fit the flat washer against the step on the selector shaft.
7. Fit the knob and lock in place with the 10-32 nut and lock washer.
8. Ensure that the knob rotates smoothly and 'clicks' positively in each position - see (5) above.

7. PARTS LISTS

When ordering spare parts, please specify the following information:

- Serial number of atomiser
- Approximate date of purchase
- Description of part
- Part number as shown in this section
- Number of parts required

7.1 AU6539 Atomiser

Item	Part No	Description	Qty	Notes
1	EX6224	Feed Body	1	
2	EX6225	Feed Ring (9 Hole)	1	
3	EX6222	Gauze Hub	1	
4	EX6223	Gauze Assembly	1	
5	EX6226	Inner Gauze	1	
6	EX6391	Washer Spacer	1	
7	EX6227	Drive Pin	1	
8	CBP2478	'O' Ring	1	
9	CBP2479	'O' Ring	1	
11	EX6277	Electric Motor 24V DC	1	Alt EX6278 12 VDC
12	CBP2093	Screw M5 x 20 Pan	4	
13	CBP2944	Washer M5	4	
14	A206 C10	Screw Csk	3	
15	CBP2267	Nyloc Nut M8	1	
16	SP127-G	Washer	1	
17	CBP2484	Elbow M/F	1	
18	EX6276	Adaptor	1	
19	EX6271	Nameplate	1	
20	CBP2813	Label	1	
21	EX6393	Separator Plate	1	
22	CBP2541	'V' Ring Seal Inner	1	

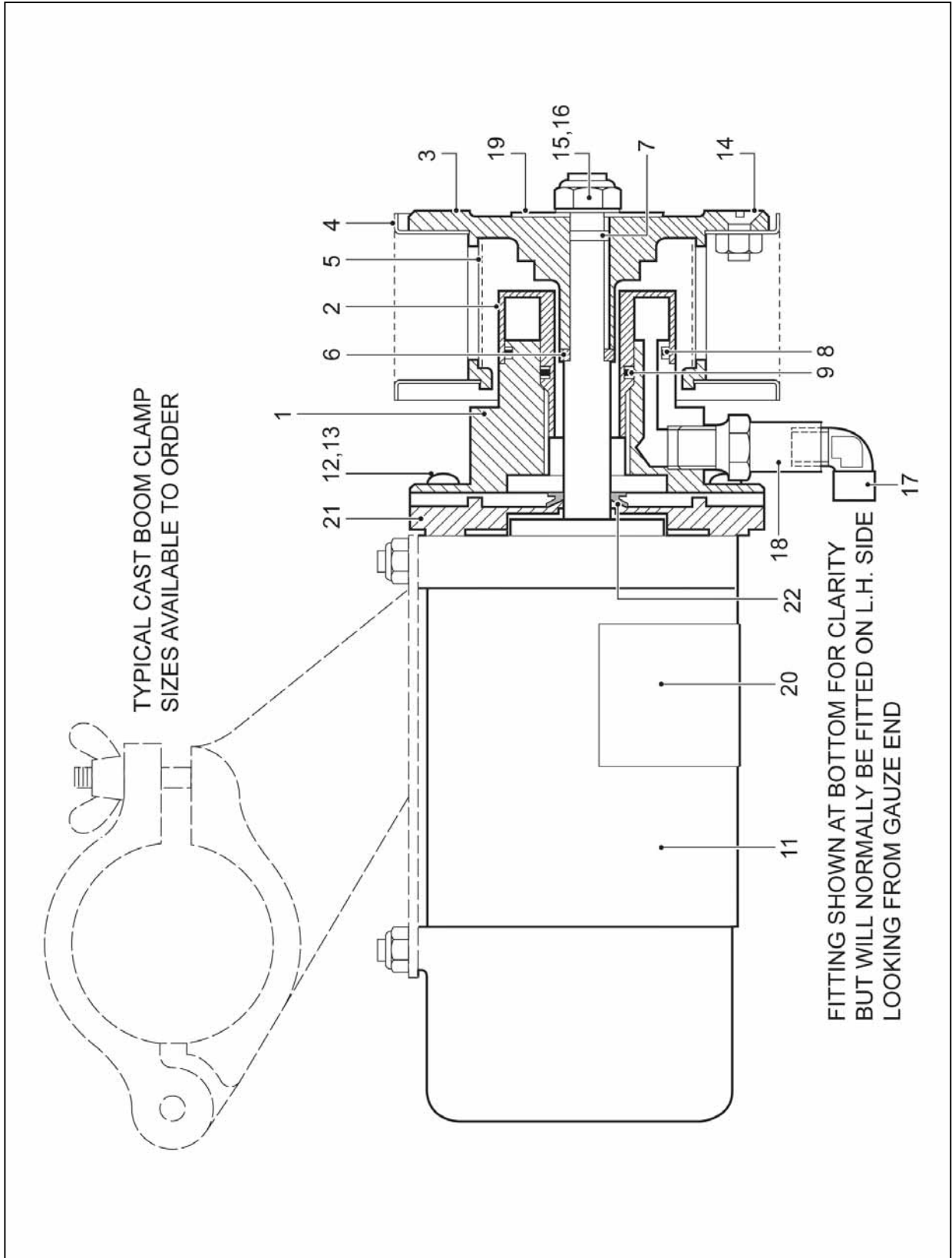

Fig. 3 – AU6539 Atomiser

7.2 EX6277 Motor

Item	Part No	Description	Qty	Notes
1	EX6277	Electric Motor Complete	1	
2	CBP2493	Spare End Cap Plastic	1	Not Shown
3	CBP2520	Spare Bearing	2	
4	CBP2521	Spare Brushes	1 Pair	

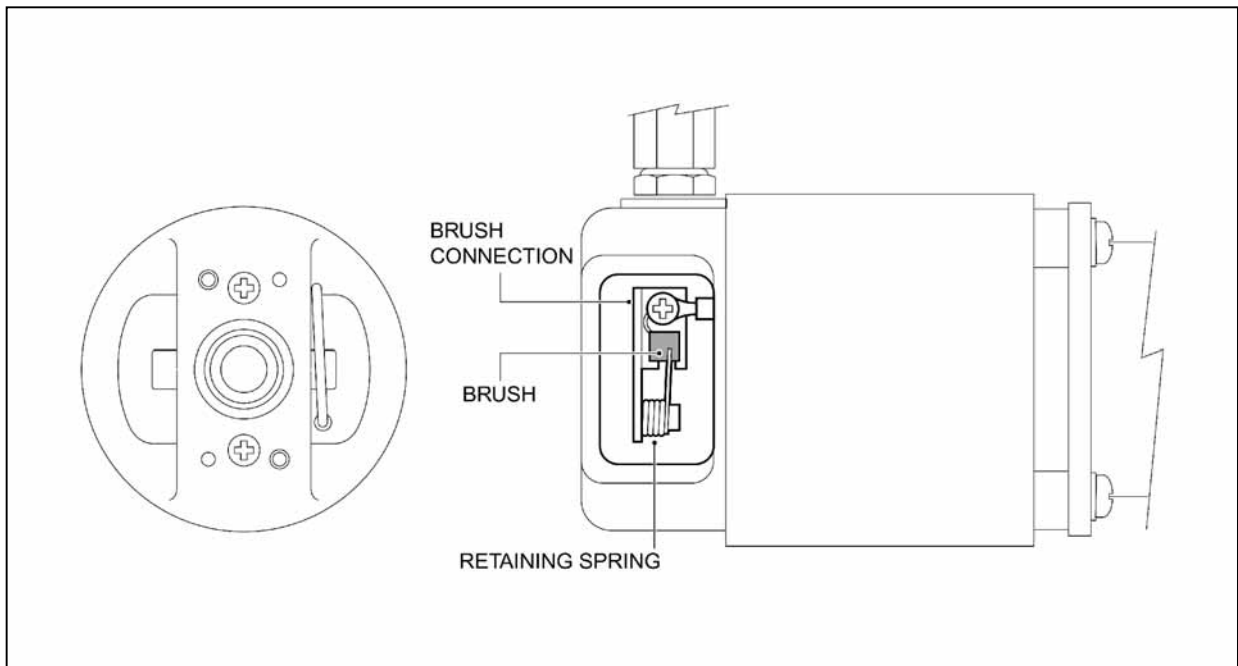

Fig. 4 – EX6277 Motor

7.3 EX6307 Variable Restrictor Unit

Item	Part No	Description	Qty	Notes
1	EX1556	Outlet Fitting	1	
2	EX194L	Restrictor Plate	1	
3	EX2081	Shaft/Selector Plate	1	
4	CBP493	Spring	1	
5	EX2078	Body Assembly	1	
6	EX2077	Spring Index	1	
7	EX72	Gland Packing	1	
8	EX71	Gland Retainer	1	
9	SP127D	Washer	1	
10	EX2069	Thimble	1	
11	AGS2037C	Washer Locking	1	
12	NAS679-A3W	Nut	1	
13	EX1670	Cap, Blanking 1/8" NPT	1	
14	EX1671	Cap, Blanking 1/4" NPT	1	

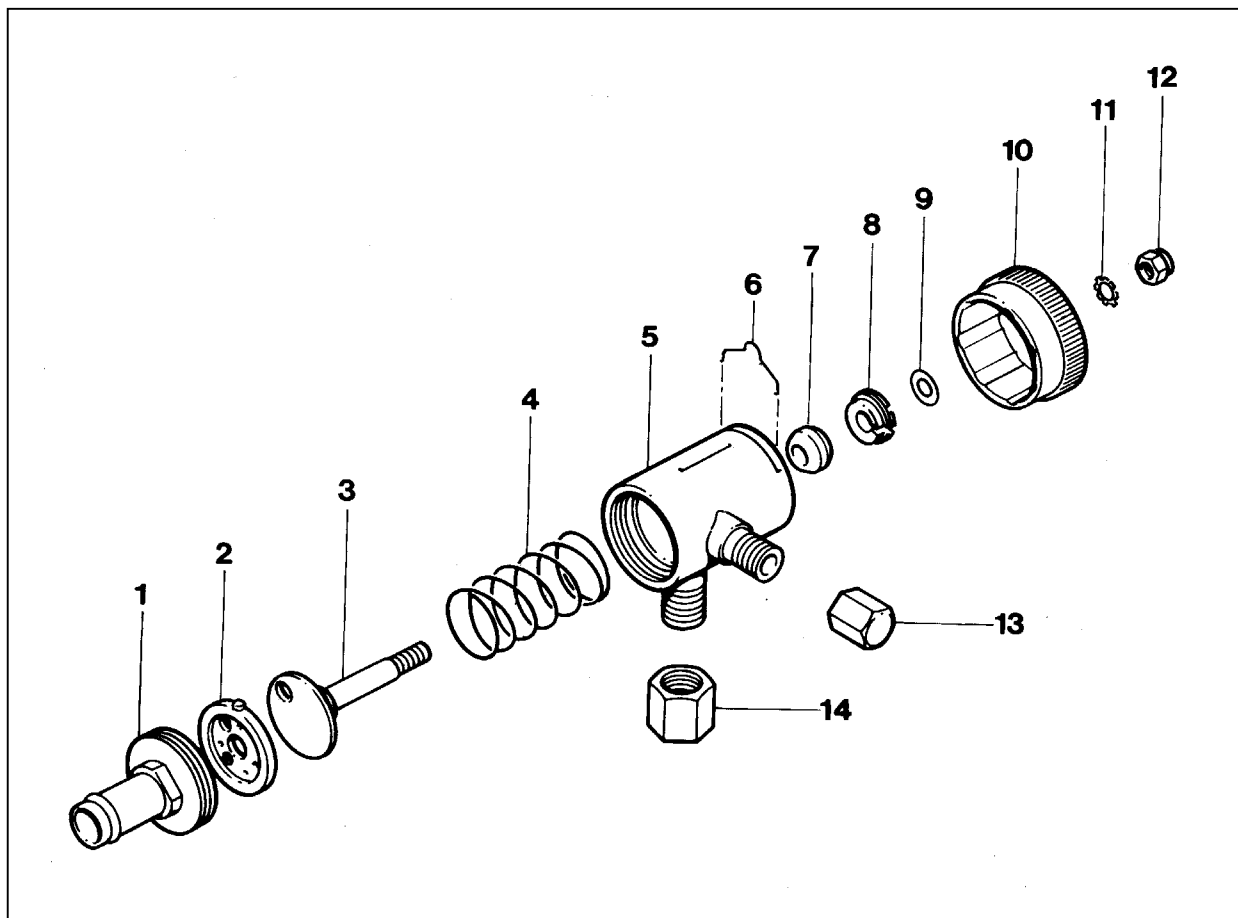

Fig. 5 – Variable Restrictor Unit

7.4 EX6306 Diaphragm Check Valve

Item	Part No	Description	Qty	Notes
1	CBP2534	Diaphragm Check Valve	1	
2	CBP1848	Diaphragm	1	Incl in Item 1
3	CBP2535	End Cap Assy	1	Incl in Item 1
4	CBP1630	Strainer	1	
5	CBP2537	Adaptor Cap	1	
6	EX6305	Adaptor	1	
7	EX1954	Inlet Tail	1	

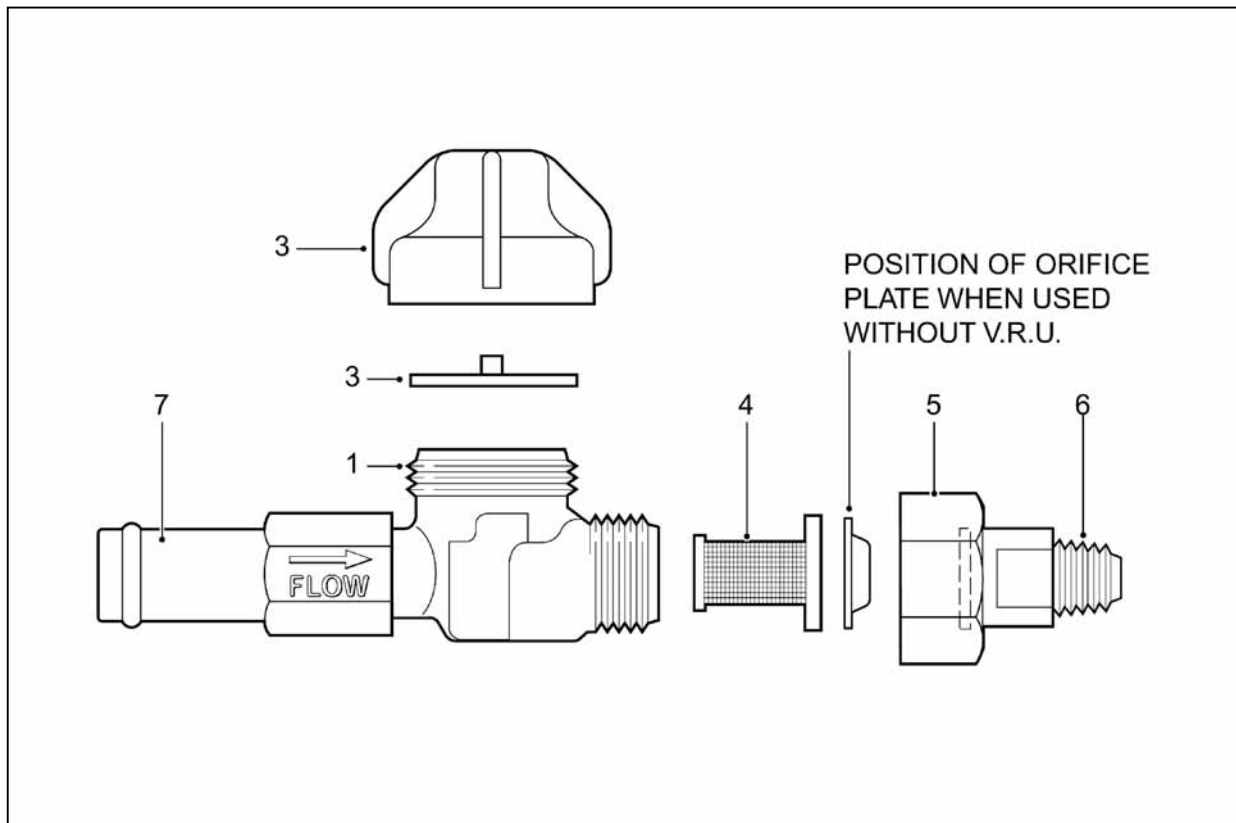

Fig. 6 – EX6306 Diaphragm Check Valve

8. ELECTRONIC SPEED CONTROLLER

The Micronair EX4195 electronic speed controller is designed specifically for use with Micronair direct drive AU6539 electric atomisers on helicopters or other aircraft. The unit can control the speed of up to six atomisers simultaneously, ensuring that they are run at the correct speed to produce the required spray droplet size.

All atomisers are controlled by a single speed control potentiometer and an on/off switch. These controls are mounted in the cockpit, either in a box on the control grip or on a panel.

The electronic unit has six fused outputs for the protection of individual atomiser motors.

The unit is intended for 24 – 28 V DC aircraft supplies only. It must not be used for any other application or with a different supply voltage.

8.1 Specification

8.1.1 Electronic Unit EX6360

Size:	8" (205 mm) L x 6" (150 mm) W (excl lugs) x 3.7" (95 mm) H
Weight:	2.6 lb (1.18 Kg)
Input Voltage:	24 – 30 V DC
Maximum Input Current:	Internally limited to 70 A
Maximum Output Current:	8 A per atomiser continuous
Protection:	By 10 A quick-blow fuse for each atomiser
Mounting:	By 10-32 (5 mm) bolts on 120 mm x 166 mm centres
Ambient Temperature:	0 – 40°C

8.1.2 Control Box EX6358

Size:	2.5" (65 mm) L x 1.2" (30 mm) W x 4.5" (115 mm) H
Weight:	0.8 lb (0.35 Kg)
Controls:	Atomiser speed control potentiometer Atomiser on/off switch

8.2 Installation

8.2.1 Installation of Electronic Unit

The Speed Controller electronic unit should be installed in a suitable position. The position chosen must:

- Provide adequate protection from rain, dust and spray liquid both on the ground and in flight.
- Be shielded from direct sunlight and be away from other sources of heat.
- Be surrounded by a sufficient volume of air and, preferably, be in a direct airflow to ensure adequate cooling.
- Be easily accessible for wiring and maintenance.

The electronic unit can be mounted in any attitude, provided that the heat-sink on the lid is not obstructed.

The unit should normally be mounted by means of the lugs provided on the back face. The mounting dimensions for these are shown in Fig. 7. Should it not be possible to use these lugs, alternative mounting holes may be drilled in the box or other brackets can be fitted. All fixings must be made to the back or sides of the box and no attachments should be made to the removable front panel.

If not using the existing fixing lugs, proceed as follows:

1. Remove the M4 screws securing the front panel to the box.
2. Remove the front panel and gasket.
3. Drill the necessary holes and de-burr. Mount the box as appropriate.
4. If any of the original lug securing holes are not re-used, they should be closed with screws, rivets or sealant.
5. Ensure that the inside of the box is completely clean and that no particles of metal swarf remain inside.
6. Replace the lid of the box, ensuring that the gasket is in position and that the screws are tightened.

8.2.2 Connection to Aircraft Power Supply

The electronic unit must be connected to the aircraft 24 – 28 V supply as shown in Fig. 8. The exact details of this connection will depend upon the configuration of the aircraft electrical system and the following notes are intended for guidance purposes only.

The maximum continuous current consumption of the controller when feeding six atomisers is 48 amps. The internal current limit of the controller prevents the inrush current exceeding 70 amps when starting the motors. When using less than six atomisers, the running current will be reduced proportionately but the total inrush current

can remain at 70 amps. Taking this into account, the controller must always be connected to a source of power able to deliver not less than 70 amps. In some installations it may be possible to make a connection to the main distribution bus bar via a suitable circuit breaker (this is not supplied with the unit as a suitable type must be selected to suit the installation). If the bus bar rating is not sufficient or the space for a circuit breaker is not available, the supply to the controller should be taken from a fuse or circuit breaker mounted immediately adjacent to the battery. If this arrangement is used, a switch (accessible from inside the cockpit) and a contactor must be provided to isolate the Speed Controller when not in use.

Regardless of how the power supply connection is made, it is the responsibility of the installer to use approved cable and components and to ensure that all parts are installed according to approved practice. Particular care must be taken with the installation of the wiring from the bus bar or battery terminal to the protection device.

The wires from the protection device to the Speed Controller unit and from the Speed Controller unit to airframe ground must be of an approved type and the size should be 8 AWG or larger.

The 24 – 28 V supply and ground wires must be connected to the M5 studs on the front panel of the unit with suitable crimp or solder tags. Wherever possible, these wires should be run well clear of any other equipment or cables that might be susceptible to electromagnetic interference.

8.2.3 Connection to Atomisers

The Speed Controller is provided with six individually fused outputs. Only one atomiser should be connected to each of these outputs. The connection between each atomiser motor and the controller output should be made with suitable approved wires of 12 AWG or larger. These wires should be terminated with suitable crimp or solder tags for the connection to the M4 studs on the front panel.

IMPORTANT: Under no circumstances should more than one atomiser be connected to each output of the controller. It is vital that both the positive (+) and negative (-) wires are connected to the controller. The negative outputs of the controller are not at ground potential and must never be grounded. Connecting either output of the controller or either motor lead to airframe ground could destroy the unit.

The wires to the atomiser must be adequately protected against contamination by spray chemical or rain and must be secured to the booms in order to prevent movement or chaffing in flight. Atomiser wiring in the fuselage area should, as far as possible, be run away from any other equipment or cables which might be susceptible to electromagnetic interference.

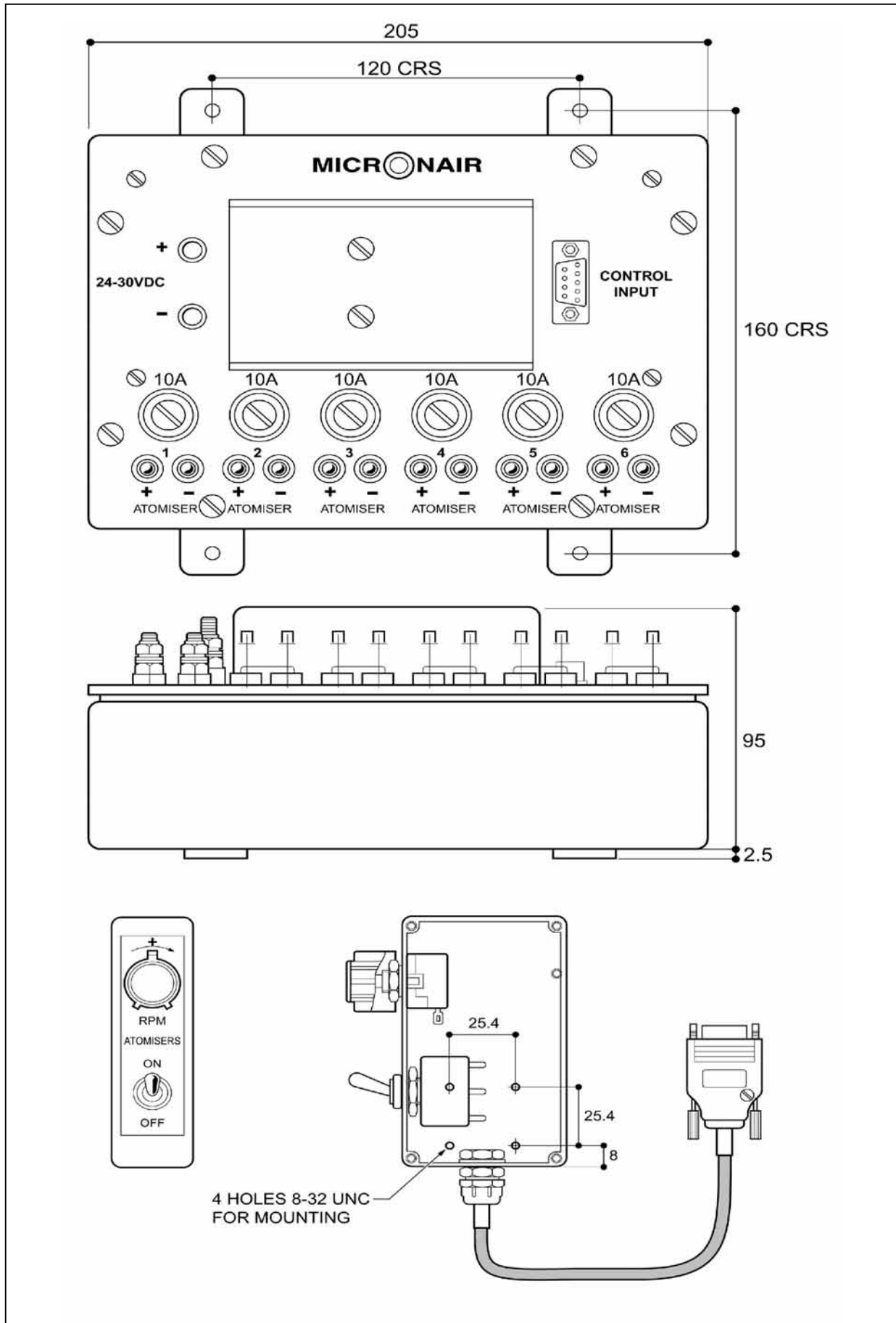

Fig. 7 – Mounting of Electronic Unit & Control Box

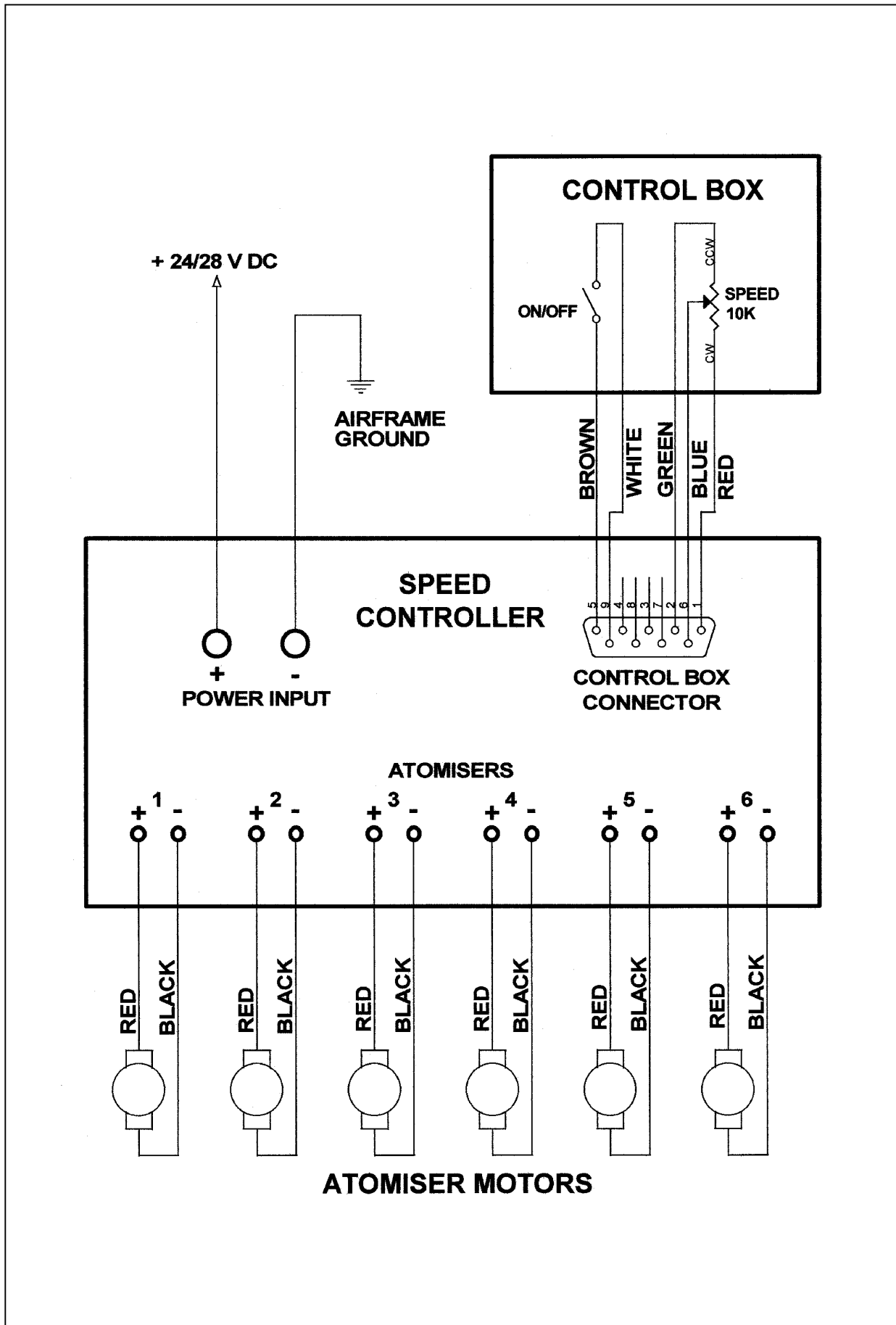

Fig. 8 – Wiring Diagram of Speed Controller Installation

8.2.4 Installation of Controls

The Speed Controller is supplied with a control box already fitted with a speed control potentiometer and atomiser on/off switch. Wherever possible, this control box should be fitted in a suitable position on the control grip or elsewhere in the cockpit. If it is not possible to use the complete box, the potentiometer and switch may be removed and installed individually. Should this be necessary, it is vital that the wires are connected as shown in Fig. 8. Note that the cable from the electronic unit to the controls is screened. Should it be necessary to change or extend this cable, screened cable must be used.

The cable from the control box is connected to the electronic unit by means of a 9 pin 'D' type connector. The plug on the cable must be secured to the socket in the controller by means of the two jack screws in the plug housing. Wherever possible, the original cable should be used. Should it be necessary to change or extend the cable, the plug should be rewired as shown in Fig. 8.

8.3 Operation

The atomisers should always be stopped and started by operating the cockpit on/off switch. If a switch or circuit breaker has been fitted to disconnect the controller from the power supply this should not be used to switch the atomisers on or off. The atomiser switch should always be in the OFF position before connecting the controller to the aircraft supply or switching on the aircraft master switch.

The speed controller potentiometer should be used to set atomisers to the correct speed before spraying. This adjustment is best carried out on the ground, using a hand-held tachometer to measure the atomiser speeds. The correct speed should be determined either by reference to the rotational speed/droplet size graph in this Handbook or by carrying out flight tests to establish the optimum droplet size at crop level.

When operating the atomiser on/off switch, it must be remembered that the atomisers take up to 1 second to accelerate to their working speed. It is, therefore, important to switch the atomisers on before entering the spraying area and before turning on the chemical supply. In normal operation, the atomisers should be left running during turns and only switched off when leaving the spray area.

8.4 Maintenance

The electronic unit contains no user serviceable parts and should be returned to the factory for repair or replacement with a service exchange unit in the event of an internal malfunction.

The controller is fitted with individual fuses for each atomiser output. A defect in an atomiser motor or its wiring will cause the corresponding fuse to blow. It is important that a fuse is not replaced until the fault has been identified and corrected.

IMPORTANT: Fuses must only be replaced with the correct type. This is 1¼" x ¼" 10 amp quick-blow. Use of a fuse of higher rating or the installation of a slow-blow type could result in permanent damage to the controller. Use of a fuse of a lower rating may result in a fuse blowing under normal operating conditions.

9. CONVERSION FACTORS

1 yard	= 3 feet	= 0.91 metre
1 metre	= 39.37 inches	= 1.09 yards
1 statute mile	= 0.87 nautical mile	= 1.61 kilometres
1 nautical mile	= 1.15 statute mile	= 1.85 kilometres
1 kilometre	= 0.62 statute mile	= 0.54 nautical mile
1 statute mile	= 1760 yards	= 5280 feet
1 nautical mile	= 2027 yards	= 6081 feet
1 kilometre	= 1094 yards	= 3282 feet
1 metre/sec	= 2.237 miles per hr	= 196.9 ft/min
1 acre	= 43560 sq feet	= 4840 sq yards
1 acre	= 4047 sq metres	= 0.40 hectare
1 hectare	= 107600 sq feet	= 11955 sq yards
1 hectare	= 10000 sq metres	= 2.47 acres
1 sq mile	= 640 acres	= 259 hectares
1 sq kilometre	= 247 acres	= 100 hectares
1 US gal	= 0.83 Imp gal	= 3.78 litres
1 Imp gal	= 1.20 US gals	= 4.54 litres
1 litre	= 0.26 US gal	= 0.22 Imp gal
1 US pint	= 16 US fl ounces	= 0.47 litres
1 Imp pint	= 20 Imp fl ounces	= 0.57 litre
1 US gal/acre	= 8 US pint/acre	= 9.45 litres/hectare
1 Imp gal/acre	= 8 Imp pints/acre	= 11.35 litres/hectare
1 litre/hectare	= 0.11 US gal/acre	= 0.081 Imp gal/acre
1 pound	= 16 ounces	= 0.45 kilogram
1 kilogram	= 2.20 pounds	= 35.3 ounces
1 ounce	= 28.35 grams	
1 pound/sq inch	= 0.068 atmosphere	= 0.067 bar
1 atmosphere	= 14.70 pounds/sq in	= 1.01 bar
1 bar	= 14.50 pounds/sq in	= 0.98 atmosphere
1 kilopascal	= 0.01 bar	= 0.145 pounds/sq in

Micronair is the registered trademark of Micron Sprayers Limited, Bromyard, Herefordshire, United Kingdom.

Every care has been taken in the design of this equipment and the preparation of this Handbook. However, Micron Sprayers Limited cannot accept responsibility for errors or the consequences thereof. The user must satisfy himself that the equipment is suited to his needs, is performing according to his requirements and that all statutory requirements and airworthiness regulations are being complied with.

